



T-DAR®

Model T1010MT One Head
Model T2010MT Two Head
Model T4010MT Four Head

Mantrap

TAILGATING / PIGGYBACKING DETECTION SYSTEM

INSTALLATION AND OPERATION MANUAL

Newton Security Inc.
443 SW 41st Street
Renton, WA. 98057 USA
www.newtonsecurityinc.com

REV. 1.0



Warning:

Modification of T-DAR Control Panel Boxes, Annunciator Panel Boxes or Camera Head Boxes Will VOID The Warranty.

INTRODUCTION

Tailgating/Piggybacking

Access control systems are the heart of most security systems. From smart cards to fingerprinting and even iris recognition technology, there are many different systems in place to restrict access to secure areas. But there is one way to completely bypass every one of these systems - with the simple act of holding the door open. Some people do this out of politeness, as we are all taught, while others are unknowingly followed through these secure doors by unauthorized persons. All access control systems, regardless of the technology used, are vulnerable to this problem.

T-DAR® Solution

Newton's patented **T-DAR®** system uses sophisticated three-dimensional optical imaging to detect Piggybacking and Tailgating through secure portals. The Newton T-DAR system detects persons and differentiates them from carts or other objects in or around the secure side of the portal and then utilizes Newton's sophisticated Stereo Machine Vision technology to identify and tag each human within the field of view of the tracking (overhead) camera. It maintains that tag on that person so long as he or she (or some portion of the person) remains in the view of the camera. That information is then combined with the data provided by the access device, door contacts and other input data to determine if the tagged person is a legal transit or is tailgating / piggybacking.

Once the status of a person is determined to not be a legal transit but to be tailgating or piggybacking, the **T-DAR** system then actuates any number of possible results, all controlled and selected from an easy to use User Interface. These alarms range from local alarm sirens, flashing lights and voice annunciation through remote alarm, real-time delivery of video of the event to security forces, activation of internal or existing DVR systems and physical events such as the locking of other doors to prevent the intruder from further penetrating the secure area.

When the T-DAR system is used in conjunction with physical barriers such as security portals, mantraps and security revolving doors, the system can prevent tailgating/piggybacking as well as detecting and alarming on those occurrences. In addition to the model described in this manual, other models of the T-DAR system are available for use in:

- Double Doors**
- Mantraps**
- Optical Turnstiles**
- Barrier Arm Turnstiles**
- Barrier Gates (Wing Style)**
- Automated Immigration Gates**
- Elevator Control**
- Escalator Direction Sensing**

- Vehicle Tailgate Detection**
- Vehicle Tracking**
- People Counting**
- Waiting Line Tracking**
- Asset Tracking and Verification**
- Population Counting**
- Directional Control**
- Time and Attendance Tracking**

Critical Elements for a Successful T-DAR Installation

The T-DAR® system does a superb job of detecting violations of access control security systems. In order to accomplish this task, the T-DAR requires several critical elements and/or signals from the doors and the access control system as detailed in this manual. Four of the most important elements are:

- 1. Door contact/door position switch signals must be immediate.** These signals must be sent to the T-DAR unit at the same time that the door is opened. Unless it can be verified that the access control system can give immediate door open signals, the T-DAR unit must have an independent circuit for this function that allows isolation from the access control system. It is recommended that mechanical switches of the roller and plunger types be avoided in favor of magnetic switch door contacts.
- 2. Adequate and consistent lighting are required for accurate operation of the T-DAR system.** The T-DAR system uses stereo video analysis to determine three-dimensional characteristics of targets and requires sufficient lighting to perform this task. Equal and consistent lighting from the ceiling down allows the system to identify and track targets in all areas of the detection pattern. Lighting from the sides or the floor is not helpful; in fact it may detract from system performance. If adequate down lighting is not currently in place, additional lighting must be added. Invisible (near IR) lighting is available from Newton.
- 3. LineLock input is critical if low frequency fluorescents are utilized for lighting.**
An ac wall-mounted transformer is included in the T-DAR control unit. If the lighting in the area that is protected by the T-DAR is provided by low frequency (older style-line frequency) fluorescents, this transformer or other low voltage AC source must be used to ensure proper operation of the T-DAR system. Any source of 6 to 30 VAC will provide the correct line locking of the T-Dar system to the building lighting.

INTRODUCTION	4
Tailgating/Piggybacking.....	4
T-DAR [®] Solution.....	4
Critical Elements for a Successful T-DAR Installation.....	5
PRODUCT DESCRIPTION.....	10
General Description	10
T-DAR Models Covered In This Manual.....	11
T-1010MT Single Head Mantrap System.....	11
T-2010MT Two Head Mantrap Systems.....	11
T-4010MT Three or Four Head Mantrap Systems	11
T-DAR Models Not Covered In This Manual.....	11
T-DAR Product List for the Systems covered by this Manual.....	12
SPECIFICATIONS.....	15
CB110MT/210MT/CB410MT Control Unit	15
S100 Annunciator	17
DC200LP Stereo Tracking Head	19
I100 Door Position Encoder.....	21
EC105 Event Camera.....	23
EA101/EA101A Cable Extender/Amplifier	25
INSTALLATION	28
Important Safety and Warning Information.....	28
Tips for a Successful T-DAR Installation.....	29
Physical Installation.....	30
Site Considerations	31
Consistent Downward Lighting.....	31
Direct Sunlight.....	31
Before You Begin	32
Local Device Placement	32
Control Unit Placement.....	32
Annunciator Unit Placement.....	32
Event Camera Placement	32
Stereo Tracking Head Selection.....	33
NTSC or PAL	33
Lighting System – Visible or Near IR	33
Distance from Stereo Camera Head to Floor.....	33
Large Mantraps.....	34

Stereo Tracking Head Placement.....	34
Stereo Tracking Head Placement chart.....	36
Component Mounting and Electrical Connections.....	37
Control Unit.....	37
Stereo Tracking Head	38
Annunciator Unit	38
Door Position Sensor (Door Encoder).....	39
CONNECTION TO ACCESS CONTROL SYSTEMS	40
Relay Connections	40
Public and Secure Door, Valid Access Switches.....	41
Protect the T-DAR from door lock voltage feedback.....	42
Door Lock Method.....	42
Door Position Switch	43
Door Position Switches for Large Mantraps.....	43
Access Valid Connections (external relay).....	44
Public and Secure Valid Access Connections (Option 1).....	44
Public and Secure Valid Access Connections (Option 2).....	44
Public Door Encoder Connection	45
Annunciator Unit	45
Supervisor Override (User Interface Bypass).....	46
Method of Operation Using a Supervisor Override Switch.....	46
CONNECTION TO LAPTOP / LAN.....	47
To Configure the Host TCP/IP Connection.....	47
Install the Software	47
User Interface (UI) Application.....	47
T-DAR Control Unit Application	48
Configure Connection.....	49
Connecting via Ethernet.....	49
Configuring the T-DAR.....	50
Viewing Images	50
Calibration.....	50
Inward Swinging Public Door	50
Testing the Units	51
Capturing Events.....	51
Configuration and Setup of the T-DAR Software	51
Components Needed for Setup	51
Setup Process	51

USER INTERFACE	53
About the T-DAR User Interface Software	53
Tab Pages.....	53
File Menu.....	54
Figure 21 – File Tab.....	54
Save Settings.....	54
Load Settings	54
Exit.....	55
Connection Menu.....	56
Connection.....	56
Disconnect.....	56
Configure Connection.....	56
Debug Tab:.....	57
Display	60
Alarm and Events.....	61
Event Camera.....	61
Setup I/O	62
Installer Camera Settings	64
Image Type	64
Update Now	64
Viewing Window	64
Physical Setup.....	65
Sensitivity	66
Minimum Head Size	66
L2, L3, and L4	66
Cart Sensitivity.....	67
Crawler Sensitivity.....	67
Installer I/O	68
Door Control	69
System Log	71
Advanced Tab	72
OPERATION.....	73
Important Safety and Warning Information.....	73
Critical elements to maintain proper T-DAR operation	74
Front Panel Indicator LED’s on the CB210.....	76
Programming the Annunciator.....	77
Troubleshooting	79

Tips for getting a good image	79
Lighting.....	79
Problems Communicating with the T-DAR	80
Imaging Problems	81
All Monitored Events Are Failing	84
DETAILED SPECIFICATIONS - CB110MT/210MT/410MT	85
Power Specifications.....	85
DC Input Specifications.....	85
Relay Output Specifications	85
Auxiliary Power Outputs	85
Control Unit Panel Connections	86
Upper Front Panel Connections.....	87
Front Panel Connections.....	88
Connection details.....	90
Video Out.....	90
Input 1	90
Relay 1	90
Relay 2.....	90
Relays 3 - 6	90
Line Lock Input.....	90
Input Common	90
RS232 TX	91
Input 4 and 6	91
Input 3 and 5	91
Input 2 and 7 -14.....	91
I100 Door Position Encoder.....	92
T-DAR Digital Outputs.....	93
Known Issues and installation Tips	98
LINELOCK INPUT	99
INDEX	100

PRODUCT DESCRIPTION

General Description

Several configurations of the T-DAR Series are available. The models covered in this manual are all inside systems and have the following features:

- ◆ Confirm only one human for each authorized entry, including multiple authorizations for each escorted visitor
- ◆ Allows for carts, parcels and other non-human objects
- ◆ Tracking and detection take place even if the portal is open for other authorized entries and exits
- ◆ Accepts data from virtually any badge or pass system, including biometrics and Smart ID systems.
- ◆ When a violation occurs, the alarm activates and the event camera records the violator in real time.
- ◆ Data, time, and pass number used for the authorized passage are recorded with the event video.
- ◆ Communicates the alarm condition and transmits the recorded video to central security in real time over a video or digital link.
- ◆ Allows door to swing in either direction.
- ◆ Fully software configurable; easily adapts to virtually any mantrap.
- ◆ All operating and communication parameters are controlled by a simple graphical user interface.

T-DAR Models Covered In This Manual

T-1010MT Single Head Mantrap System

- ◆ For smaller mantraps up to 5' (1.5M) X 5' (1.5M)
- ◆ Swing Doors
- ◆ Sliding Doors
- ◆ Folding Doors
- ◆ Any combination of doors
- ◆ Multiple door entries to the mantrap

T-2010MT Two Head Mantrap Systems

- ◆ For larger mantraps up to 5' (1.5M) X 10' (3.0M)
- ◆ Swing Doors
- ◆ Sliding Doors
- ◆ Folding Doors
- ◆ Any combination of doors
- ◆ Multiple door entries to the mantrap

T-4010MT Three or Four Head Mantrap Systems

- ◆ For larger mantraps up to 10' (3.0M) X 10' (3.0M)
- ◆ Swing Doors
- ◆ Sliding Doors
- ◆ Folding Doors
- ◆ Any combination of doors
- ◆ Multiple door entries to the mantrap

T-DAR Models Not Covered In This Manual

- ◆ One or Two Independent Door Systems
- ◆ Double Door Systems
- ◆ Gate (Turnstile) Systems
- ◆ Outside Systems
- ◆ Vehicle Systems
- ◆ People Counting Systems
- ◆ Population Counting
- ◆ Elevator Systems (Internal to the Elevator)
- ◆ Thrown Object Detection Systems
- ◆ Escalator Systems
- ◆ Revolving Doors
- ◆ Time and Attendance Tracking
- ◆ Waiting Line Tracking
- ◆ Directional Control Systems

Consult Sales at Newton Security Inc. for T-DAR Models and Manuals for systems not covered in this manual.

T-DAR Product List for the Systems covered by this Manual

Please use the following data when contacting your sales representative for additional components. Special configurations are also available.

	Item	Model Number	Description
1.	1 Head Complete Mantrap T-DAR System	T1010MT	Complete Mantrap Tailgate Detection System-with CB110MT Control Unit, 1 DC 200LP Camera Head, and 1 S100 Annunciator Unit
2.	2 Head Complete Mantrap T-DAR System	T2010MT	Complete Mantrap Tailgate Detection System-with CB210MT Control Unit, 2 DC 200LP Camera Heads, and 1 S100 Annunciator Unit
3	4 Head Complete Mantrap T-DAR System	T4010MT	Complete Mantrap Tailgate Detection System-with CB410MT Control Unit, 4 DC 200LP Camera Heads, and 1 S100 Annunciator Unit
4.	1 Head Mantrap Control Unit	CB110MT	Single Head Mantrap Control Unit
5.	2 Head Mantrap Control Unit	CB210MT	Two Head Mantrap Control Unit
6.	4 Head Mantrap Control Unit	CB410MT	Four Head Mantrap Control Unit
7.	Stereo Camera Head	DC200LPLP	Stereo Camera Unit
8.	Annunciator Unit	S100	Wall Mount Annunciator Unit with Light, Siren and Voice Alarm
9.	Door Position Sensor	I100	Door Position Sensor- Required for doors where door swing intrudes into the field of view of the T-DAR unit (Door swings into the secure area).

9.	Event Camera	EC105	Color Event Imager
11.	Cable Extender/Amplifier	EA101/EA101A EA101 powered by the T-DAR unit EA101A powered by plug mounted power supply	Cable Extender--Extends the distance from the door to the T-DAR Control Unit for more than the standard 200'. Extends the cable length for the DC200LPLP Stereo Camera Head, the S100 Annunciator Unit and the I100 Door Position Indicator. EA101 units can be combined for up to 1,000' from the door to the T-DAR Control Unit. Installs DC200LPLP into Drop Ceiling Panels
12.	Ceiling Mount Kit	MK200LP	
13.	Wall Bracket	WB100	Stereo Camera Head wall mounting bracket-used for mounting a DC200LPLP to a flat wall
14.	Two Man Rule Software (Includes multiple man rules)	F111	Requires Two, or if specified, more than Two humans at each transaction
15.	Space Occupancy Software	F112	Keeps track of the number of humans occupying the secure space
16.	Thrown Object Detection Software	F102	Option to detect thrown objects up to 60 Miles Per hour
17.	Anti-Pass Back Software	F103	Option to determine if persons with a valid access signal have proceeded through the portal
18.	Non-standard I/O Software	F104	Customer specified I/O differing from the standard T-DAR software
19.	Non-standard Operating Software	F105	Customer specified Operating software differing from the standard T-DAR operating software

20. *Authorized Cart Software* F106

Software allowing specific individuals to move special carts through the T-DAR system or that allows specific Authorized Carts to be recognized and to pass through the T-DAR system

SPECIFICATIONS

CB110MT/210MT/CB410MT Control Unit



Figure 1- T-DAR Control Unit

Size: 5.726" x 16.365" x 11.643"

Weight: 26 lbs

Enclosure: Bent steel; completely enclosed with door

Mounting: Mounting via 4 x 1/4 " holes on back panel tabs (Optional mounting brackets available)

Standard Operating Temperature: 40 to 110 degrees F, (optional high and low temperature systems available)

Storage Temperature: 0 to 125 degrees

Power Considerations

The T-DAR Systems requires relatively stable DC power. If the system is installed in an area where the DC power is not stable and is subject to severe fluctuations and/or discontinuity, the use of an Uninterruptible Power Supply may be required.

Input Voltage/Current	24VDC Listed (26VDC MAX) @ 8A
Inputs	14 Opto-isolated digital
Outputs	6 Relays 3A each
Video out	VGA, NTSC / PAL (Software Selectable)
Connectors	Phoenix style, BNC (RG-59U and RJ45)
Serial Connections	2 RS232 and 4USB

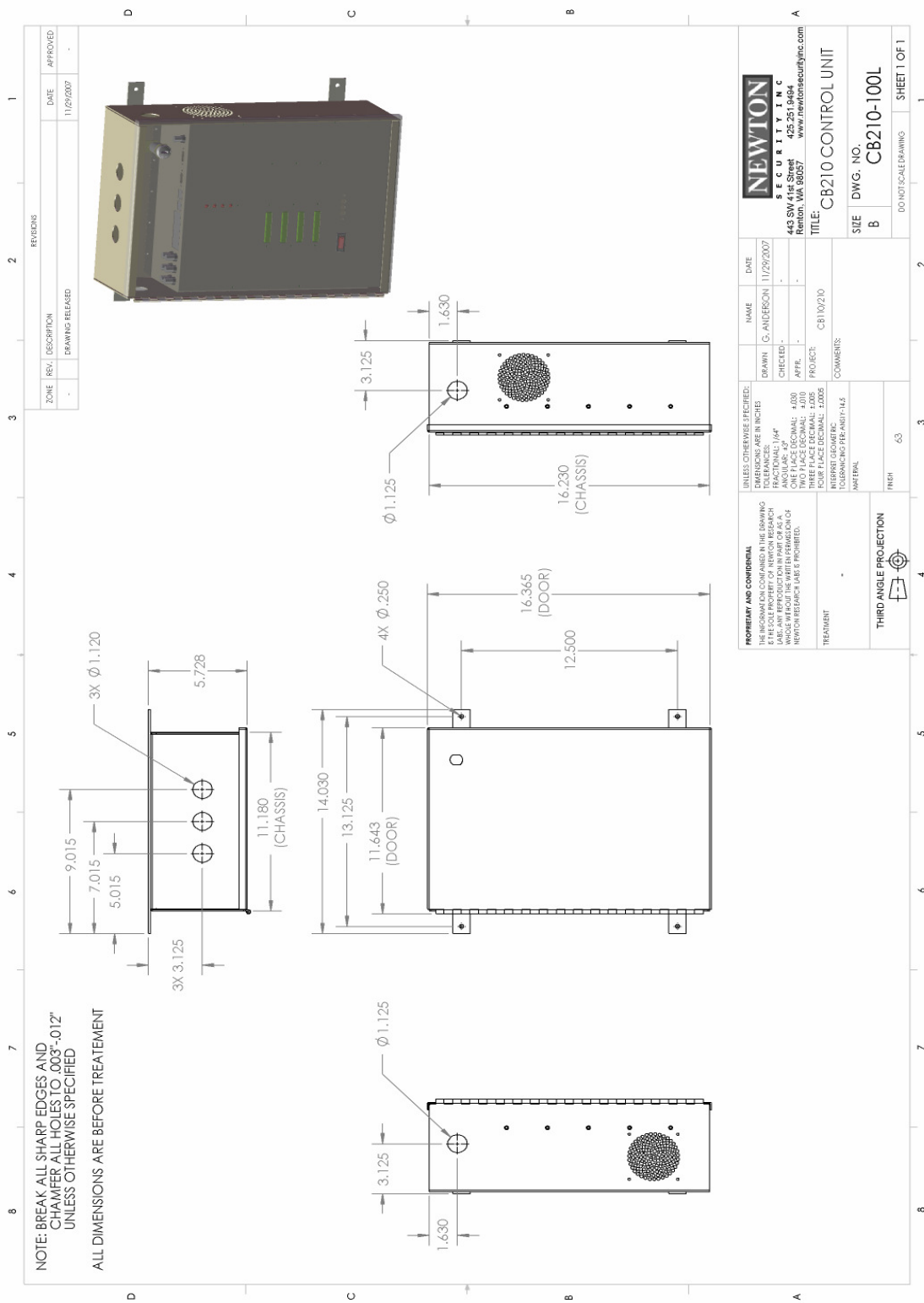

Figure 2 - T-DAR Control Unit CAD

S100 Annunciator



Figure 3 - T-DAR Annunciator

Size: 6.00" x 8.13" x 7.19"

Weight: 5 lbs

Enclosure: Bent steel, with high impact plastic indicator

Mounting: Mounting via 4 x 3/16" holes on back panel tabs

Standard Operating Temperature: 40 to 125 degrees F, (optional high and low temperature systems available)

Storage Temperature: 0 to 150 degrees F

Input Voltage/Current

12VDC 2A maximum (*Powered by the CB200 Control Unit*)

Inputs

RJ45 Std. Ethernet Cable from Control Unit

Speaker Volume Control
Illuminator

Rotary Control with front panel access
Xenon Strobe w/red colored diffuser

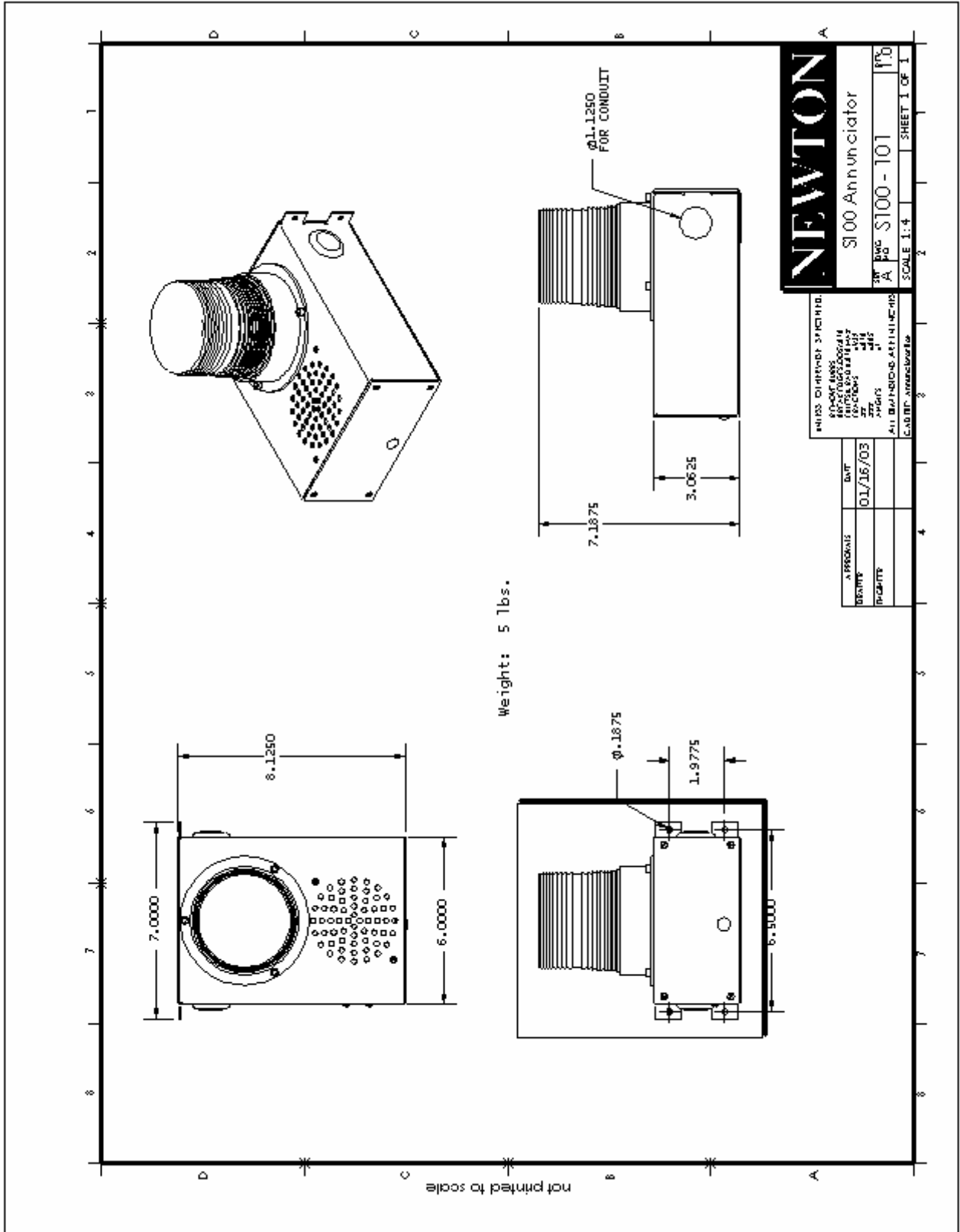

Figure 4 - T-DAR Annunciator CAD

DC200LP Stereo Tracking Head



Figure 5 - T-DAR Stereo Tracking Head

Size: 7.00" x 2.50" x 2.50"

Weight: 2.2 lbs

Enclosure: Bent steel

Mounting: Mounting via 4 x 1/8" holes on back panel tabs (Optional mounting brackets available)

Standard Operating Temperature: 40 to 125 degrees F, (optional high and low temperature systems available)

Storage Temperature: 0 to 150 degrees F

Input Voltage/Current	12VDC 1A maximum (<i>Powered by the CB100/200 Control Unit</i>)
Inputs	1-RJ45 Std. Ethernet from Control Unit
Outputs	NTSC or PAL Stereo Video (Specify)
Video Connectors	BNC x2 (RG-59U)
Focus and Field of View	Factory fixed, non-adjustable (Correct part number must be specified for the application camera height. Consult the table on Page 38 for the lens specification and part number)
Lighting	Both Visible and Near IR (Invisible to human eyes) DC200 camera heads are available

Figure 6 - T-DAR Stereo Tracking Head

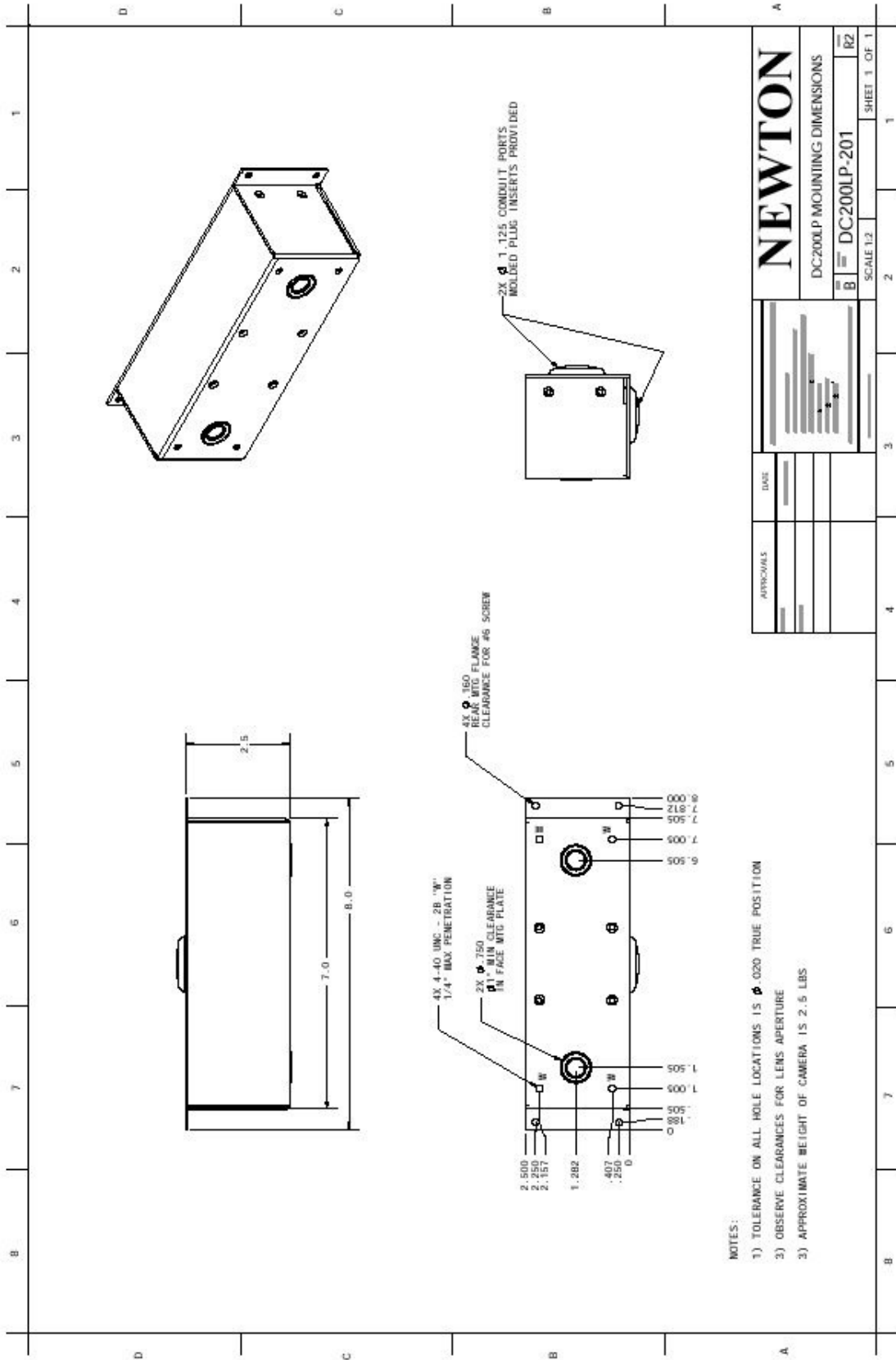

NOTES:

- 1) TOLERANCE ON ALL HOLE LOCATIONS IS \pm .020 TRUE POSITION
- 2) OBSERVE CLEARANCES FOR LENS APERTURE
- 3) APPROXIMATE WEIGHT OF CAMERA IS 2.5 LBS

APPROVALS	DATE			DC200LP MOUNTING DIMENSIONS B = DC200LP-201 SCALE 1:2 RZ	SHEET 1 OF 1

I100 Door Position Encoder



Figure 7 – T-DAR Door Encoder

Size: 2.40" x 2.50" x 2.40"

Weight: 13.5 ounces

Enclosure: Machined Delrin

Mounting: Mounting via 4 x 1/4-" holes on back panel (Optional mounting brackets available)

Standard Operating Temperature: 40 to 125 degrees F, (optional high and low temperature systems available)

Storage Temperature: 0 to 150 degrees F

Input Voltage/Current

12VDC 500mA maximum (*Powered by the CB100/200 Control Unit*)

Inputs

RJ45 Std. Ethernet from Control Unit

Outputs

Quadrature digital output

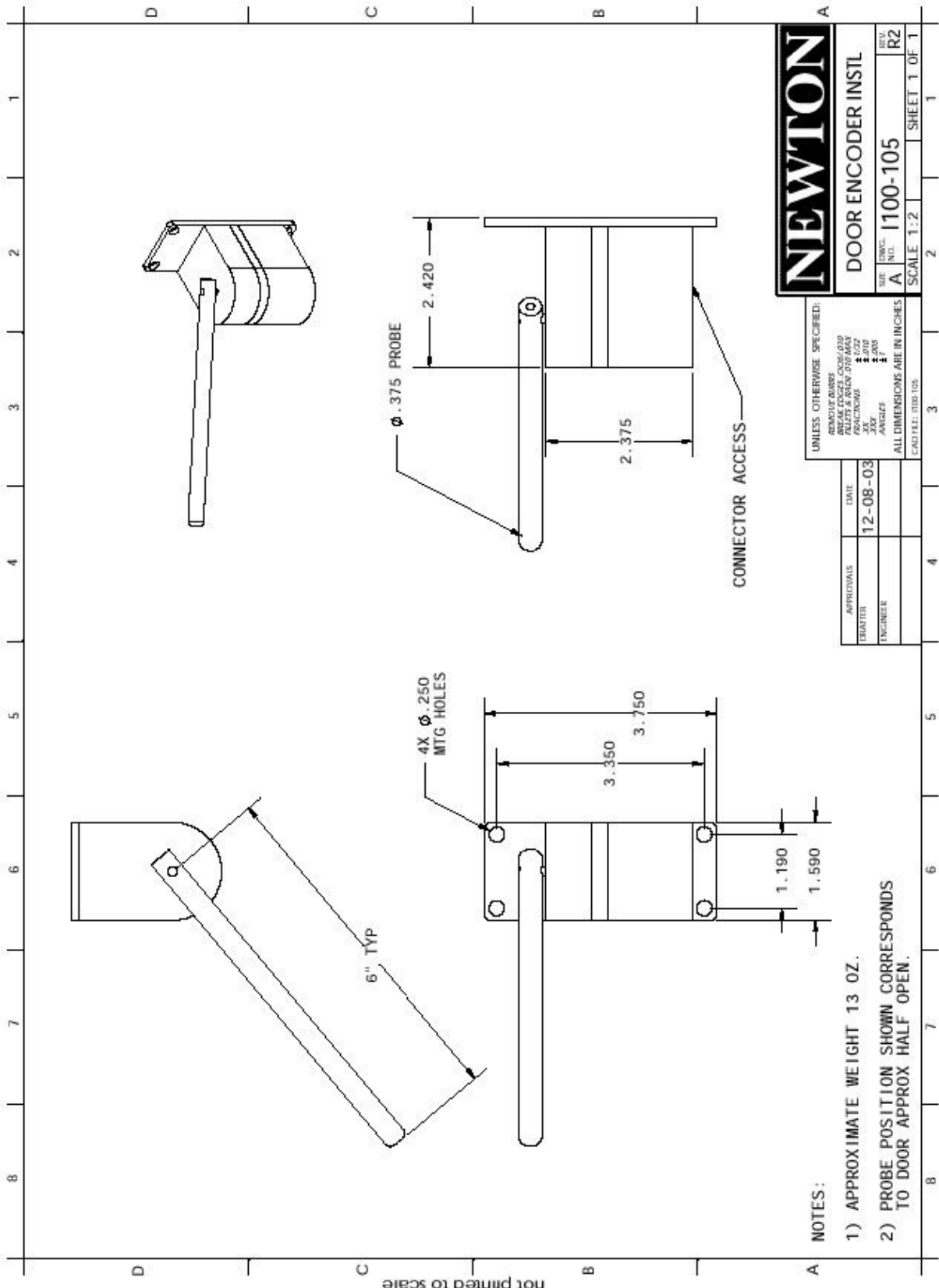

Figure 8 – T-DAR Door Encoder

EC105 Event Camera



Figure 9 – T-DAR Event Camera

Size: 2.13" x 1.81 x 2.36

Weight: 10 Ounces

Enclosure: Extruded Aluminum

Mounting: Mounting via 1 1/4-20 indexed threaded hole on top cover (Optional mounting brackets available)

Standard Operating Temperature: 40 to 125 degrees F, (optional high and low temperature systems available)

Storage Temperature: 0 to 125 degrees F

Input Voltage/Current
Inputs

12VDC/24VAC .5A
12 DC or 24VAC Screw Terminals
Note: For 2 door systems, event cameras must be AC powered to allow Linelock between cameras

Outputs

NTSC or PAL Video (Customer Specified)

Video Connector

BNC (RG-59U)

Focus

User adjustable

Lens

Supplied without Lens (Unit requires CS mount lens) Lenses are available from Newton-specify at time of order

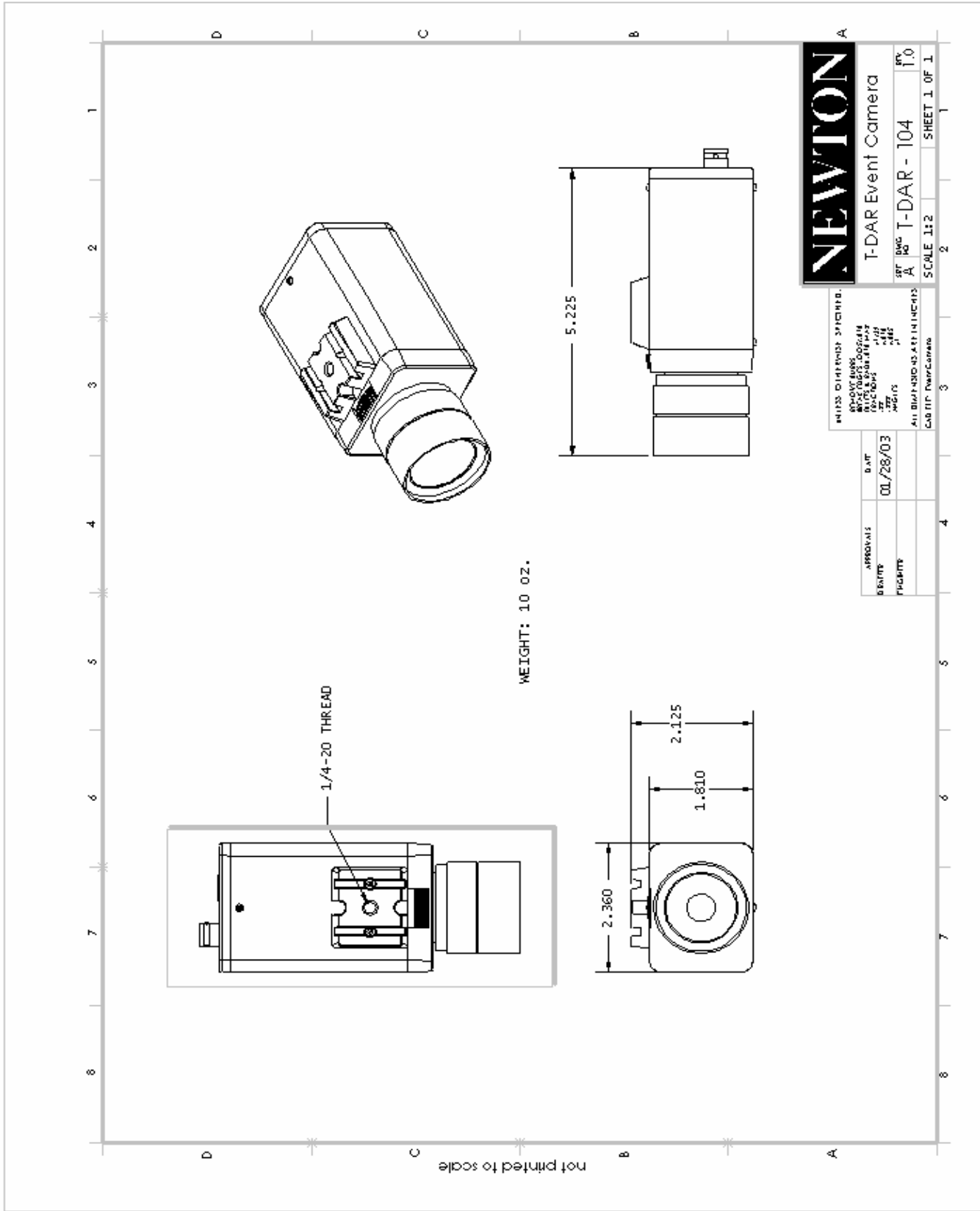

Figure 10 – T-DAR Event Camera

EA101/EA101A Cable Extender/Amplifier



Figure 11 – T-DAR Cable Extender/Amplifier

Size: 3.55" x 3.55" x 3.00"

Weight: 1.5lbs

Enclosure: Extruded Aluminum

Mounting: Mounted via back panel mounting holes

Standard Operating Temperature: 40 to 125 degrees F, (optional high and low temperature systems available)

Storage Temperature: 0 to 125 degrees F

Required to extend the standard maximum distance of 200' from the door to the CB100/200 Control Unit

Input Voltage/Current

EA101 powered by the T-DAR Control Unit-no external power required
EA101A-supplied plug mounted power supply-115/230 VAC 50-60Hz 28 Watts
2 BNC (RG59U)

Inputs (From the protected door)

2- Stereo Cameras from the DC200LPLP
2 RJ45 (Standard Ethernet Jack)
1- DC200LP Stereo Camera Head Power
1- S100 Annunciator Unit

Outputs (To the DC100/200 Control Unit or additional EA101A Extender/Amplifier)

2 BNC (RG59U)
2- Stereo Cameras
2 RJ45 (Standard Ethernet Jack)
1- DC200LP Stereo Camera Head Power
1- S100 Annunciator Unit

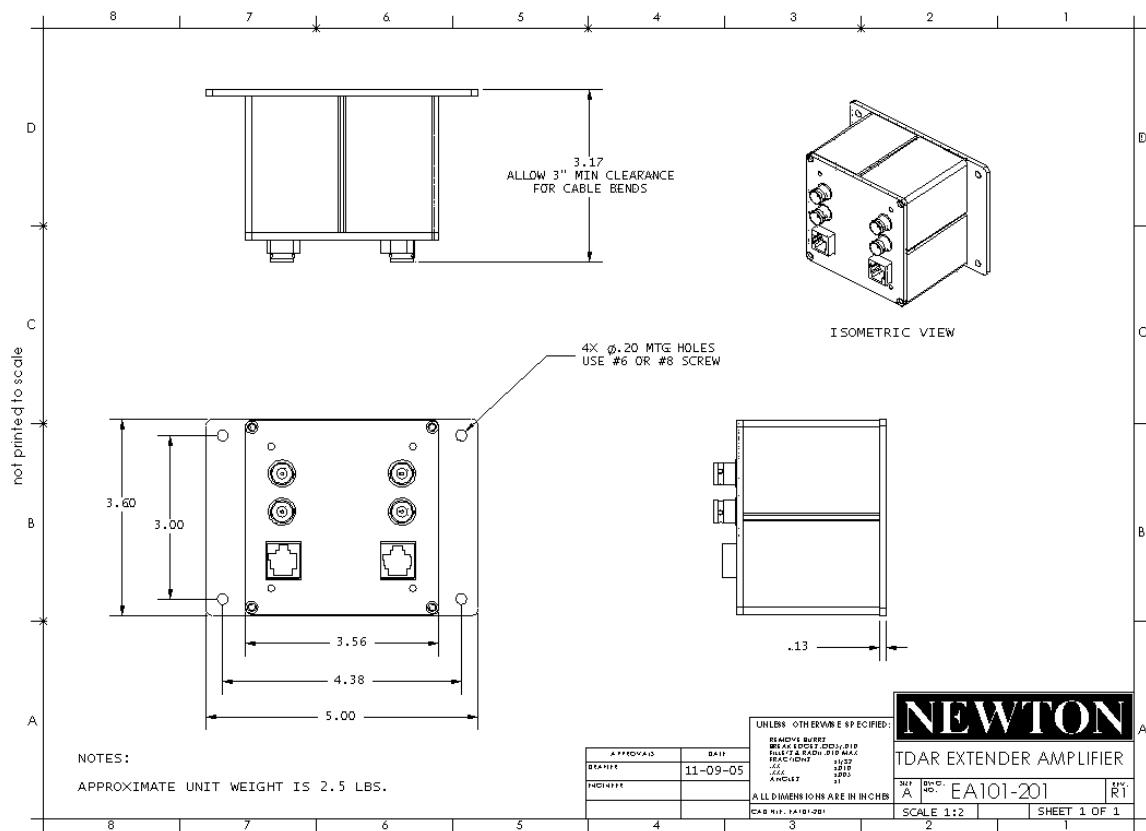

Figure 12 – T-DAR Cable Extender/Amplifier CAD

Ea101 Vs. Ea101A



Figure 13 - EA101

- Use the EA101 for the first extender at 150 – 200 feet
- No external power require-powered from the TDAR Control Unit

Vs.



Figure 14 - Ea101A W/ power adapter

- Use the EA101A for additional extenders for each 150- 200 foot extension
- Power from a plug mounted power adapter-supplied with the EA101A
- Able to daisy chain up to 4 units for a total of 1,000 foot cable runs
- 120/240VAC 50/60Hz 28W

INSTALLATION

Important Safety and Warning Information



WARNING Electrical Shock Hazard with Cover Removed

The T-DAR system may contain, produce and present the hazard for electrical shock or burns with the cover removed. There are no user serviceable parts under the interior panels. Only trained authorized personnel may perform maintenance or repair.

Underwriters Laboratories Inc. has not tested the performance or reliability of the security or signaling aspects of this product. UL has only tested for fire, shock and casualty hazards as outlined in UL's Standard for Safety UL 60950-1. UL Certification does not cover the performance or reliability of the security or signaling aspects of this product. **UL MAKES NO REPRESENTATIONS, WARRANTIES OR CERTIFICATIONS WHATSOEVER REGARDING THE PERFORMANCE OR RELIABILITY OF ANY SECURITY OR SIGNALING RELATED FUNCTIONS OF THIS PRODUCT.**

Units are for use in **RESTRICTED ACCESS LOCATIONS.**

WARNING:

Modifying the enclosure or opening the enclosed electronics of the T-DAR Control Box will void the manufacturer warranty.

Modifying T-DAR Control Box enclosure by drilling/cutting/bending may damage the unit by debris and excess vibrations.

Tips for a Successful T-DAR Installation

Six of the most critical fundamentals are:

- 1. Door contact/door position switch signals must be immediate.** These signals must be sent to the T-DAR unit at the same that the door is opened. Unless it can be verified that the access control system can give immediate door open signals, the T-DAR unit must have an independent circuit for this function that allows isolation from the access control system. It is recommended that mechanical switches of the roller and plunger types be avoided in favor of magnetic switch door contacts.
- 2. Adequate and consistent downward lighting are required for accurate operation of the T-DAR system.** The T-DAR system uses stereo video analysis to determine three-dimensional characteristics of targets and requires sufficient lighting to perform this task. Equal and consistent lighting from the ceiling down allows the system to identify and track targets in all areas of the detection pattern. Lighting from the sides or the floor is not helpful; in fact it may detract from system performance. If adequate down lighting is not currently in place, additional lighting must be added. Invisible (near IR) lighting is available from Newton.
- 5. The DC200LP Stereo Camera Head must be mounted at the proper distance from the door and the proper camera part number must be specified.** Use the chart found in this manual to determine the correct distance. If the DC200LP Stereo Camera head is mounted at other distances, the T-DAR unit will not be able to properly track persons and may have erratic behavior.
- 6. Inward Swinging public doors must use an I100 Door Position Indicator.** If an I100 Door Position Indicator is not used for doors that swing into the field of view of the camera, erratic operation will result.

7. LineLock input is critical if low frequency fluorescents are utilized for lighting.

An ac wall-mounted transformer is included in the T-DAR control unit. If the lighting in the area that is protected by the T-DAR is provided by low frequency (older style-line frequency) fluorescents, this transformer or other low voltage AC source must be used to ensure proper operation of the T-DAR system. Any source of 6 to 30 VAC will provide the correct line locking of the T-Dar system to the building lighting.

Physical Installation

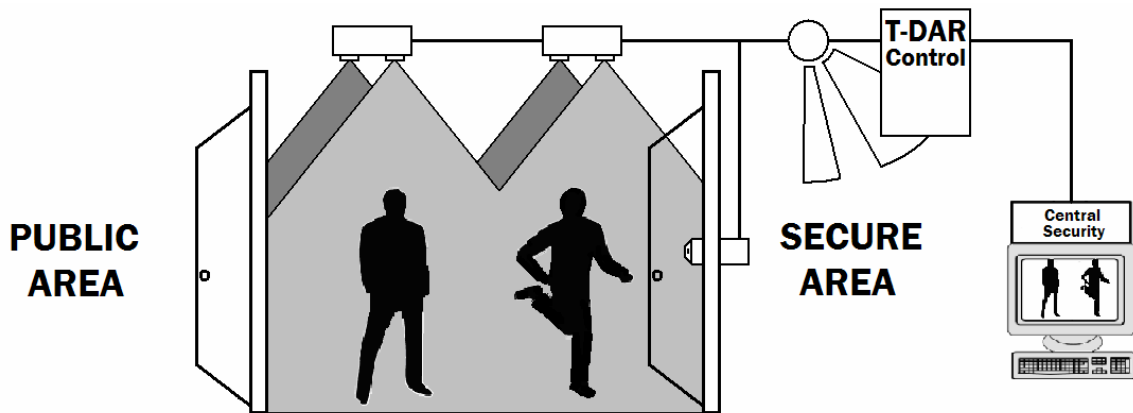

Figure 15 - Typical Configuration

Site Considerations

There are several factors that must be considered when determining the application of T-DAR for the solution of tailgating and piggybacking. These factors are detailed as follows:

Consistent Downward Lighting

The T-DAR requires adequate and consistent downward lighting to properly detect tailgate violations. Failure to provide adequate lighting will result in elevated false alarm rates as well as the possibility of the system failing to detect violations. The minimum acceptable lighting level is 300 Lux (30 Ft-Candles) from above. The measurement should be taken so that only lighting emanating from above (the ceiling in most cases) is included in the measurement. Lighting from the sides of the viewing area can actually detract from the robustness of the installation. In some cases it may be necessary to add additional lighting above the desired detection area to produce the required results. Invisible (near IR) lighting is available from Newton if desired to enhance lighting without human interference.

Direct Sunlight

Direct sunlight can have a negative impact on system performance. Proposed locations that are awash in direct sunlight should be qualified by the manufacturer.

Before You Begin

Before you begin any installation, make sure that the proposed installation locations that have been chosen provide adequate room for the devices as well as any electrical conduit that may be necessary. Dimensions for the specific components may be found in this manual

Local Device Placement

The local devices such as the door position sensor, camera head, and Annunciator Unit need to be placed within a certain linear distance of the controller to minimize the effects of voltage drop. This distance is 200 feet, and should not be exceeded unless a distance extender is used. Information about the cost and part number of the Data Extender is available from the Newton Security. Whenever possible, local devices shall be placed on the secure side of the portal being monitored to reduce the risk of vandalism and attempts to defeat.

Control Unit Placement

The Control Unit should be located in a place that allows for access to the unit, is relatively clean, and affords the unit protection from damage or vandalism. The unit should be located within an acceptable distance to the access control system so that door status signals and inter-system communications and signals are not significantly diminished by voltage drop. Adequate clearance should be maintained to the sides and top of the unit to facilitate the installation of conduit and ventilation, and clearance to the front of the unit should meet or exceed the requirements established for electrical panels by the National Electrical Code (NEC). The Control Unit is not water-tight, and must be protected from rain and sprayed or blown water.

Annunciator Unit Placement

The Annunciator Unit needs to be located at the security portal being monitored so that violations are immediately announced to the violator as well as the persons in the secure area. The Annunciator Unit is fitted with conduit knockouts on the left and right sides of the unit. Adequate clearance should be maintained to the sides of the unit to facilitate conduit installation. Additionally, adequate clearance is required to the front of the unit to allow for adjustment of the volume control. The Annunciator Unit must be installed outside of the field of view of the stereo camera head.

Event Camera Placement

The event camera should be strategically placed to capture full frontal images of persons entering the secure area through the portal. The event video output leads should be protected within armored conduit to help prevent tampering. Protecting the camera itself is recommended.

Stereo Tracking Head Selection

The stereo camera heads must be correct for your application: NTSC or PAL, Visible or Near IR lighting. Choose the correct stereo camera heads for the distance from the camera head to the floor.

NTSC or PAL

Order the correct head for your countries system. The Control Unit inputs either type of system (software selectable) and the video output will be set to the corresponding output in the T-DAR User Interface.

Lighting System – Visible or Near IR

Order the correct head for the lighting at your installation. Newton Security supplies Stereo Camera Heads for both types of lighting systems.

Distance from Stereo Camera Head to Floor

Newton Security supplies stereo camera heads pre-focused and set to the correct field of view for various camera heights. Select the correct head number from the table below. Failure to use the correct camera head for your application **will result in the failure of the installation**. In addition, the T-DAR User Interface will not allow the installation to proceed if the correct camera head has not been chosen for your application.

Stereo Tracking Head Placement

The stereo camera head needs to be located based upon the calculations in the camera head placement chart. Failure to place the camera in the correct location will lead to false alarms or an altogether failure to detect violations. The calculations in this chart are based upon door size, camera head height, and lens focal length.

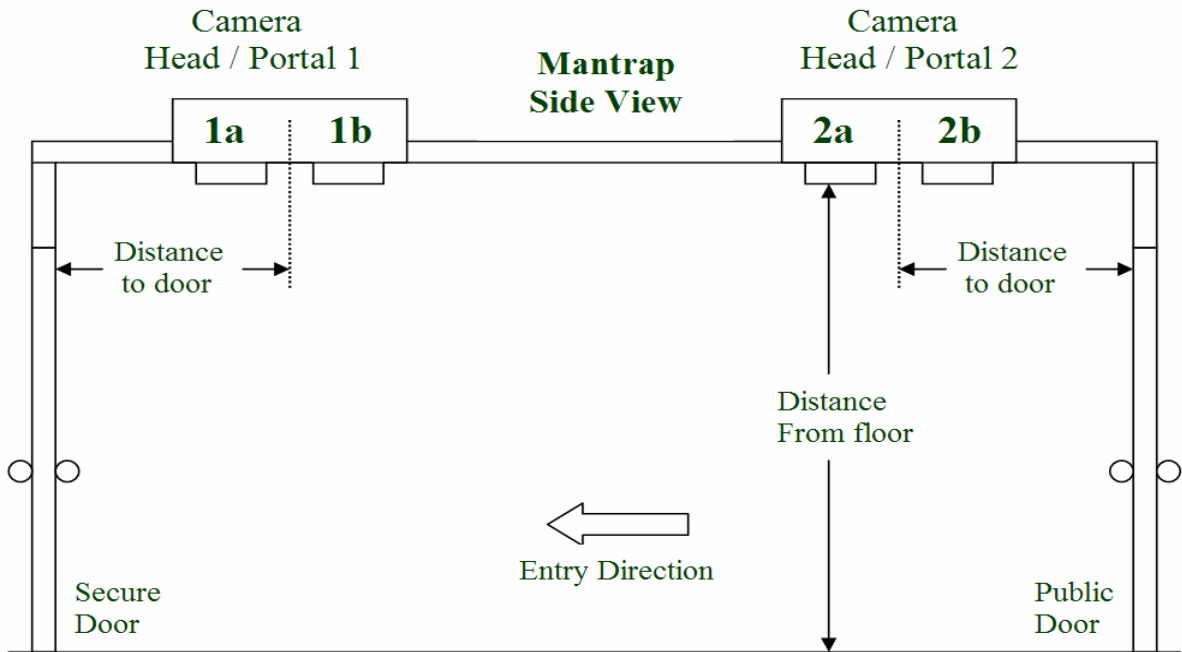

Figure 16 - Stereo Tracking Head Reference

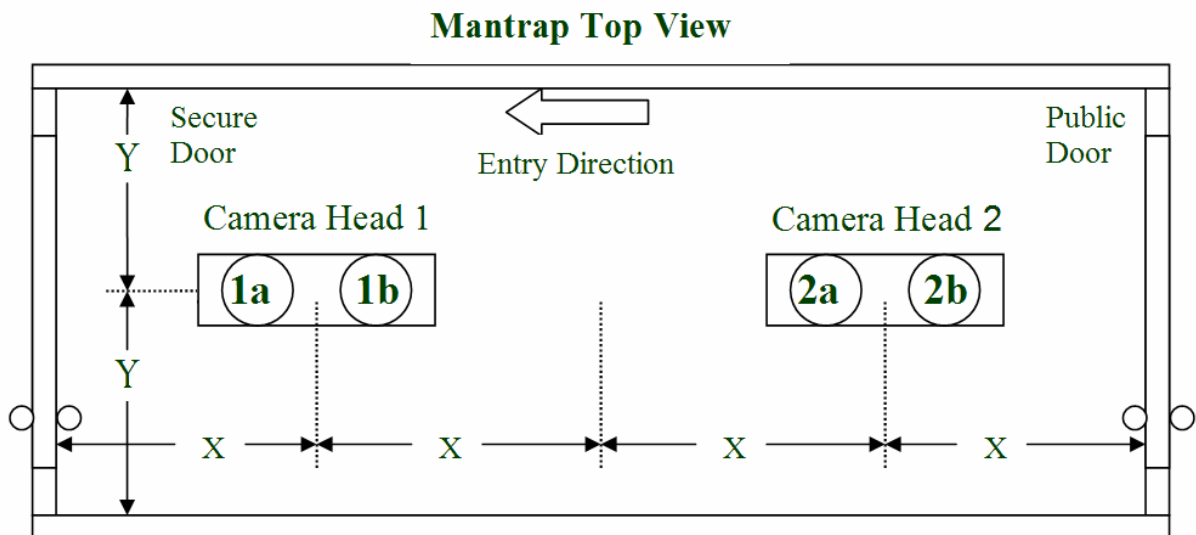

Figure 17 - Stereo Tracking Head Reference

Tracking Head Placement in Mantraps with Three or More Heads

The placement of camera heads in a large mantrap, which requires more than two heads, will vary depending on the installation. Types of installation may include double doors for the public and/or secure portals. Some installations will have doors at opposite ends of the mantrap space (as shown below), whereas others will have the public and secure doors on the same wall of the mantrap. Any configuration can be configured and will require a version of software designed for the specific space. For information on non-standard installation types, contact Newton Security, Inc. or your T-DAR system distributor.

Sample Installation Type for a Large Mantrap

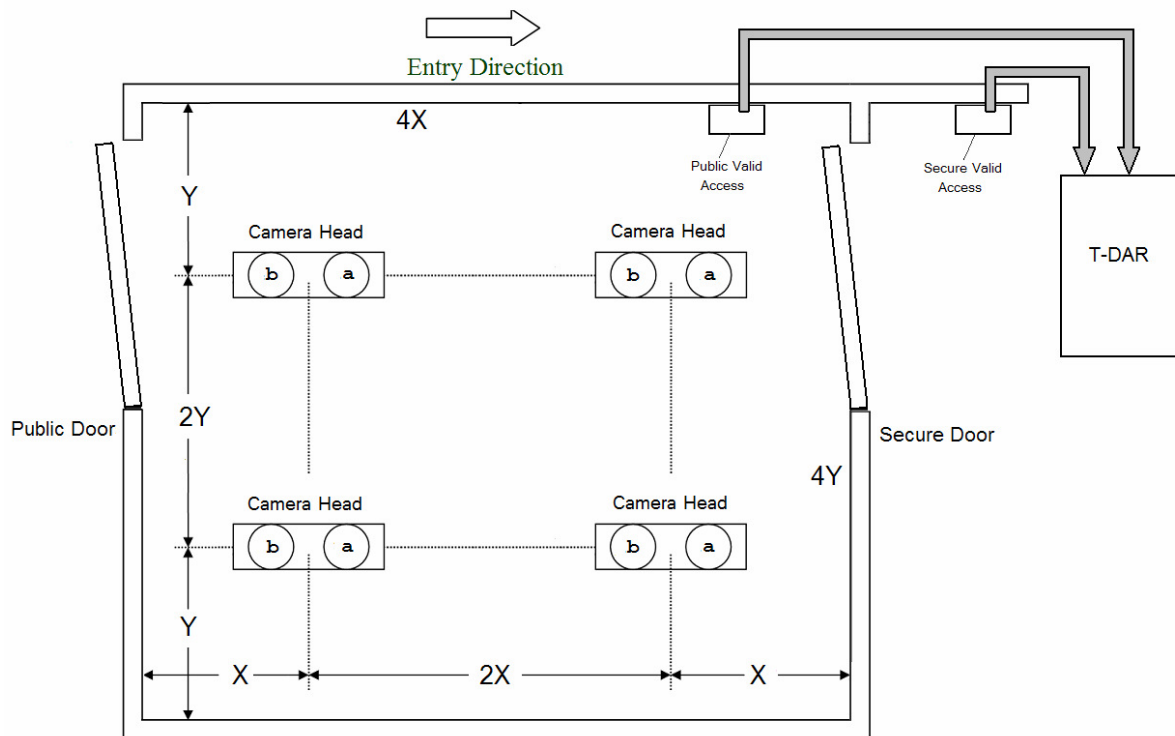

Figure 17b – Stereo Tracking 4 Head Reference

Stereo Tracking Head Placement chart

Distance from the center of the Stereo Camera Head to the door (A)		Distance from the front of the Stereo Camera Head to the floor (B)		Type of Camera
Inches	CM	Inches	M	
*	*	84 to 96*	2.1 to 2.44*	*
12-20	31-51	96 (8')	2.44	DC 219 Stereo Camera Head
12-20	31-51	100	2.54	DC 219 Stereo Camera Head
12-20	31-51	104	2.64	DC 219 Stereo Camera Head
09-20	23-51	107	2.71	DC 219 Stereo Camera Head
9-21	23-53	110 (9')	2.74	DC 225 Stereo Camera Head
9-21	23-53	114	2.95	DC 225 Stereo Camera Head
9-21	23-53	120 (10')	3.05	DC 225 Stereo Camera Head
12-21	23-53	121	3.07	DC 229 Stereo Camera Head
12-21	23-53	126	3.20	DC 229 Stereo Camera Head
12-21	23-53	132 (11')	3.37	DC 229 Stereo Camera Head
*	*	Over 132 (11'')*	Over 3.37*	*

*** Non-standard Installation. Consult factory for assistance**

(Examples of non-standard installations are any installation under 8 FT (2.44M) or over 11 FT (3.37M))

Please see figure 16 for Installation Guide

Component Mounting and Electrical Connections

Control Unit

The T-DAR control unit should be mounted on a wall in a vertical orientation. The unit is equipped with mounting tabs that will accommodate ¼ inch mounting hardware. The unit should be mounted and grounded in accordance with National Electrical Code (NEC) guidelines. The unit is not weatherproof, and will require protection from rain or sprayed water. There are four conduit knockouts on the sides and top of the unit. The control unit should not be modified as this may cause damage to the unit and will void the warranty. Refer to Figure 2 for unit dimensions.

1. For each Camera Head, install and terminate two video coaxial cables (75 Ohm) from each camera with BNC connectors. Label the cables so that cameras 1a, 1b, 2a, and 2b are all easily distinguishable. - If a three head or four head system is being installed, label additional cables 3a, 3b, 4a, and 4b, as described.
2. Attach the coaxial cables to the upper panel Tracking Camera BNC inputs in accordance with the labeling on the panel. Be sure that the camera head at the secure door is connected to BNC ports 1a and 1b. The camera head at the public door should connect to BNC ports 2a and 2b. - For a three or four head system, connect the additional cables as described.
3. For both the secure camera head and public camera head, install and terminate an Ethernet cable (straight through) at the T-DAR control box.
4. Attach the camera head 1 and camera head 2 Ethernet cables to the Camera 1 and Camera 2 connectors on the upper panel.
5. Install and terminate one Ethernet cable (straight through) from the Annunciator Unit.
6. Attach the Annunciator Unit Ethernet cable to the Annunc 1 connector on the upper panel.
7. Install and terminate an adequate number of wires to support the inputs and outputs that will be utilized on the system. Detailed examples of connections are available in Figure 17.

Stereo Tracking Head

The camera head can be mounted utilizing the mounting tabs that accommodate up to a number 12 screw or a Newton MK200 ceiling mount kit designed to work in a variety of applications such as drop tile ceiling or hard ceiling. Refer to the MK 200 manual addendum in this manual for specific details. Care should be taken to ensure adequate access to the connection port on the side of the unit. Refer to Figure 6 for unit dimensions. Mounting additional heads for a three head or four head mantrap does not constitute a standard setup, as there are additional variables to consider, such as number of doors and the mantrap shape. Consult your T-DAR System distributor or Newton Security Inc. for three and four head installation.

1. Ensure that the stereo tracking heads are mounted at the correct locations according to the chart in Figure 16. Camera head 1 should be closest to the secure door and camera head 2 should be closest to the public door.
2. Ensure that the view of the cameras is not obscured by the Annunciator Unit or any other objects such as exit signs or door closers/operators.
3. For each stereo camera head, install and terminate two video coaxial connectors with BNC connectors. These cables should already have been labeled to make them easily identifiable.
4. Attach the coaxial cables to the BNC 90 degree connectors on the inside of the stereo camera head. The camera head can be opened by removing the screws in the access plate of the unit.
5. Install and terminate one Ethernet cable (straight through) in the stereo camera head.
6. Attach the Ethernet cable to the Power/Control connector on the stereo camera head.
7. For both Camera Heads 1 and 2, ensure Camera a (1) is closest to the secure door and Camera b (2) is further from the secure door.

Annunciator Unit

The Annunciator Unit is mounted utilizing the mounting tabs that accommodate up to a number 12 screw. Care should be taken to ensure adequate access to the connection port on the top of the unit, as well as the volume control on the front of the unit. The unit should be mounted at least eight feet above the finished floor. Refer to Figure 4 for unit dimensions.

1. Ensure that the Annunciator Unit is mounted outside of the field of view of the stereo camera heads.
2. Install and terminate one Ethernet cable (straight through) on the Annunciator Unit.
3. Attach the Ethernet cable to the annunciator connector on the Control Unit.

Event Camera

The event camera should be mounted in accordance with the manufacturer's requirements. It is strongly recommended that vandal-resistant camera enclosures and wire ways be incorporated in the installation.

1. Terminate and install one video coaxial cable at the event camera.
2. Terminate and install the power supply power cable (Power must not be obtained from the T-DAR controller, a separate power supply must be provided for the installation).
3. Adjust the focus and other settings as required to obtain a usable image.
4. Adjust the sync settings of the camera per the manufacturers' procedure to optimize the quality of the event video playback to be streamed out of the T-DAR control unit.

Door Position Sensor (Door Encoder)

The Door Position Sensor is used to define the specific location of an inward swinging public door at all points of the arc that the door crosses and is required for mantrap public doors that swing into the field of view of the tracking head. This allows the T-DAR to ignore the image signature of the door and focus instead on tracking objects of interest. See Figure 7 for a picture of the Door Position Sensor

The Door Position Sensor is mounted on the secure side of the public door on the door frame above the top hinge if possible, otherwise as high as is practical. The unit must be oriented so that the arm rides on the surface of the door throughout the entire arc without encountering any resistance. The cable for connecting the sensor should be fished out of the wall/frame and terminated into the unit. The cable is a straight through Ethernet (cat 5) cable terminated with an RJ-45 connector. The other end of the cable is then terminated as flying leads on the Portal/Head2, phoenix connector D, as described in figure 35.

Note: the cable length should be no more than 200 ft linear from the controller. Use an EA101 or EA101A extender for cable runs more than 200 Feet,

Door Position Sensor for Mantraps with Multiple Public Doors

Large mantraps may contain multiple public doors (special software required). Large mantraps with multiple public doors will require a Door Position Sensor on every public door that swings inward (swings under tracking camera).

The Door Position Sensor is mounted on the secure side of the public door on the door frame above the top hinge if possible, otherwise as high as is practical. The unit must be oriented so that the arm rides on the surface of the door throughout the entire arc without encountering any resistance.

CONNECTION TO ACCESS CONTROL SYSTEMS

Relay Connections

The T-DAR T-2010 control units are equipped with four relays on the General 1 connector plus one relay on each of the Portal connectors. These relays may be used to signal various alarm conditions based on user configurable options in the user interface. All of these relays are single pole/single throw, and are normally open. Various degrees of customization are possible through coordination with the manufacturer. Refer to Figure 15 for detailed examples.

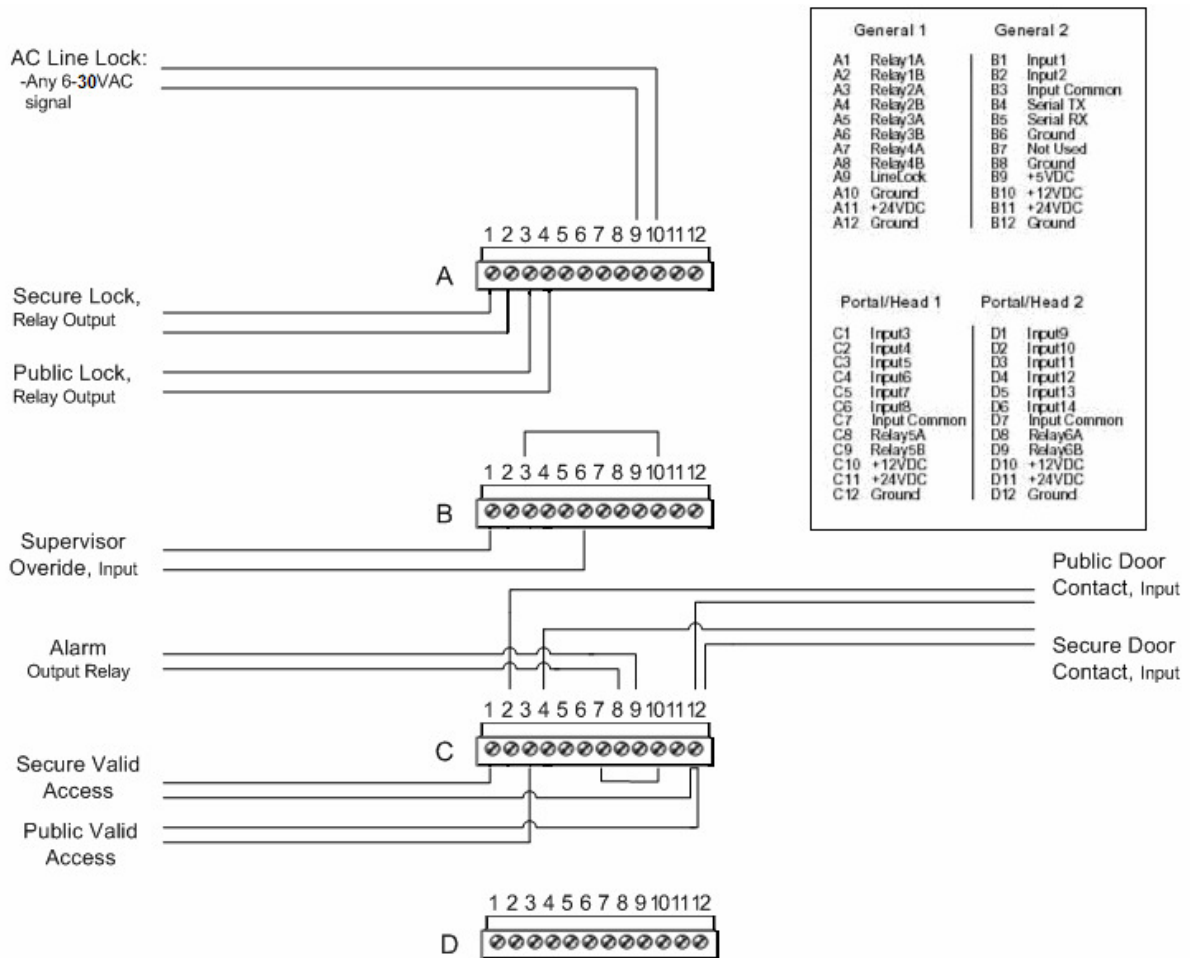

Figure 17 - Typical Configuration

Notes:

- All input grounds are common.
- All relays are SPST/Form A, with a default state of normally open.
- Reference voltage for all inputs is generated via a jumper between +12VDC and common.

Public and Secure Door, Valid Access Switches

Each valid access grant switch must be electrically isolated from the access control system to allow for proper operation. This will typically require the installation of a double pole/double throw relay that controls the lock and also provides an output to the T-DAR system. This is required when access through the mantrap is on a one-by-one basis, meaning that only one person may enter the mantrap when the public door is opened, and the door must fully close before the next person may enter the mantrap. This is necessary to ensure that there is no noticeable latency in the receipt of a valid access grant signal by T-DAR and the actual release of the door lock.

It should be noted that it is acceptable for the T-DAR to receive the signal before the door is unlocked, but not after. Failure to use isolated circuits or using access control system auxiliary outputs/relays to simulate valid access switch activity may result in poor system performance. There can be no noticeable latency in the receipt of valid access grant switch signals by T-DAR.

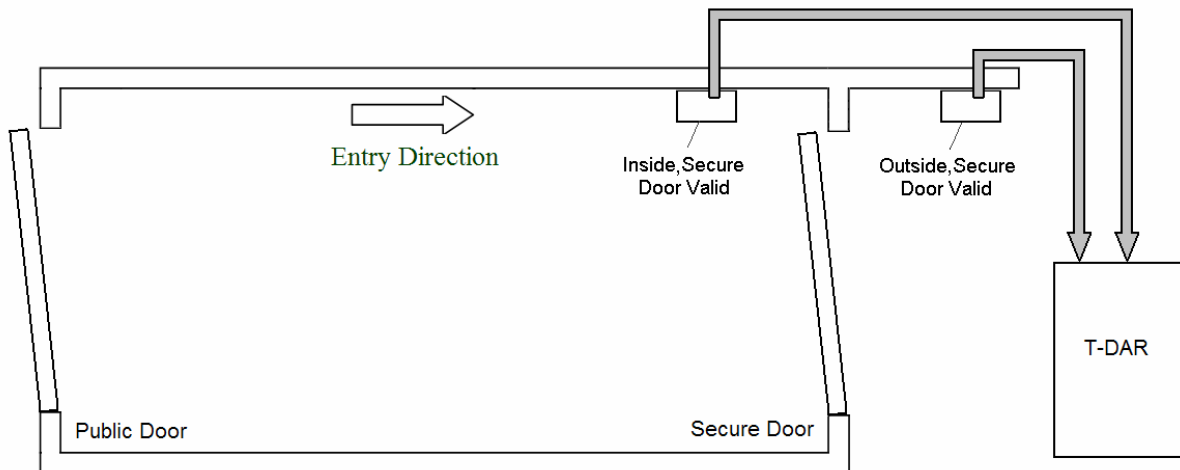

1. The valid access grant signals will connect to the Input 3 and Input 5 terminals and to either ground or +12v (or applicable source voltage) dependant upon installation type.
2. The distance from the control unit to the valid access grant switch should be kept to less than 200 foot. Contact the manufacturer for guidance on longer distances.
3. Reference voltage for all inputs is generated via a jumper between +12VDC and ground.

Protect the T-DAR from door lock voltage feedback

When using an electric solenoid locks, reverse voltage diodes across the solenoid terminals must be used to reduce voltage feedback to the system. Failure to use external relays with the Chexit, or similar solenoid locks, will damage the T-DAR control box. Be sure to connect the jumper between input common and the correct reference connection (12V or ground)

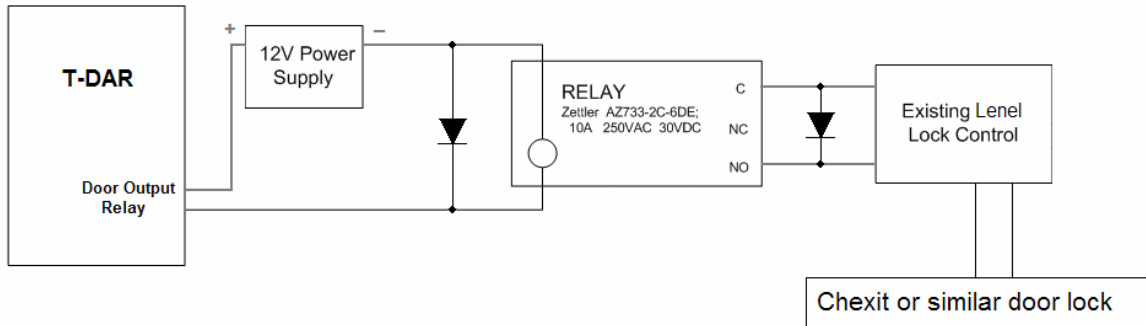

Door Lock Method

All locked doors controlled by the access control system should maintain their control of the door locks, whether the T-DAR unit is powered on or off, with one exception. The exception is that, the T-DAR unit should be able to lock one or both doors, regardless of the state of the access control. The diagram below shows a single T-DAR unit controlling the public and secure door locks, in parallel with the access control system. Each door will lock, only when the T-DAR unit AND/OR the access control system locks it.

Public Door Lock

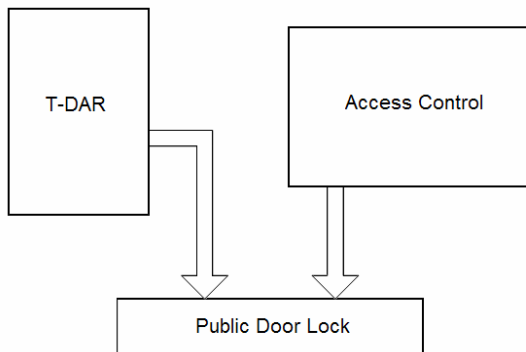

Secure Door Lock

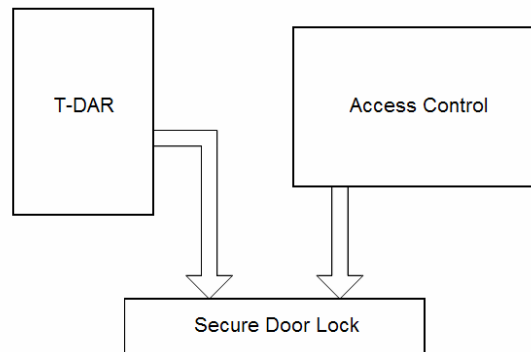

Door Position Switch

The door position (door contact) switch must be independent of the access control system to allow for proper operation. This will typically require the installation of a double pole/double throw door switch, or the addition of a second door contact. Failure to use isolated circuits or using access control system outputs/relays to simulate door contact activity can result in poor system performance. There can be no noticeable latency in the receipt of door position switch signals by T-DAR.

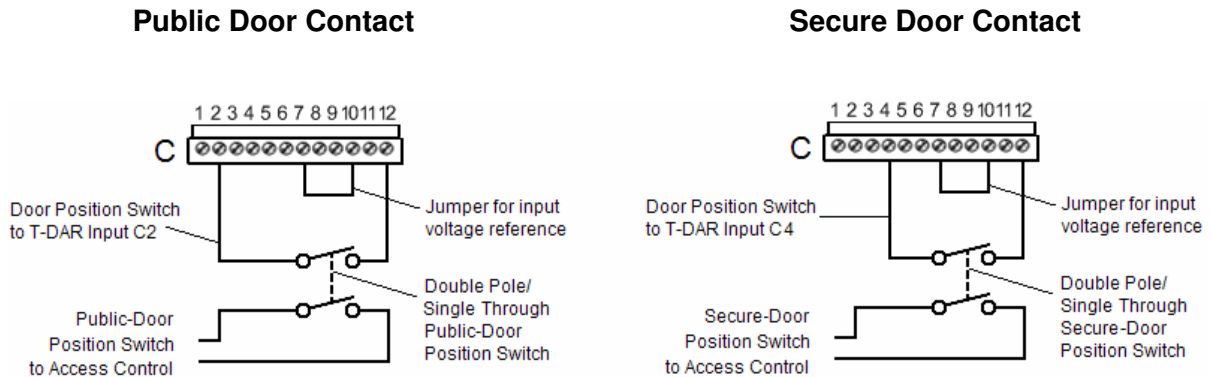

Figure 15 - Typical Configuration

1. The door position switch will connect to the Portal Contact terminal and to either ground or +12v (or applicable source voltage) dependant upon installation type.
2. The distance from the control unit to the door position switch should be kept to less than 200 foot. Contact the manufacturer for guidance on longer distances.
3. All input grounds are common.
4. Reference voltage for all inputs is generated via a jumper between +12VDC and ground.
5. Refer to Figure 15 for detailed examples of configuration.

Door Position Switches for Large Mantraps

Follow the above procedure when wiring a Large Mantrap. When multiple doors are used on the public and/or secure sides of the mantrap, connect all public doors in series and all secure doors in series. These will signal two difference input signals on the T-DAR control unit: public door contact (input 4), and secure door contact (input 6).

Access Valid Connections (external relay)

The valid access grant switch must be electrically isolated from the access control system to allow for proper operation. This will typically require the installation of a double pole/double throw relay that controls the lock and also provides an output to the T-DAR system. Here are two methods of integration.

Public and Secure Valid Access Connections (Option 1)

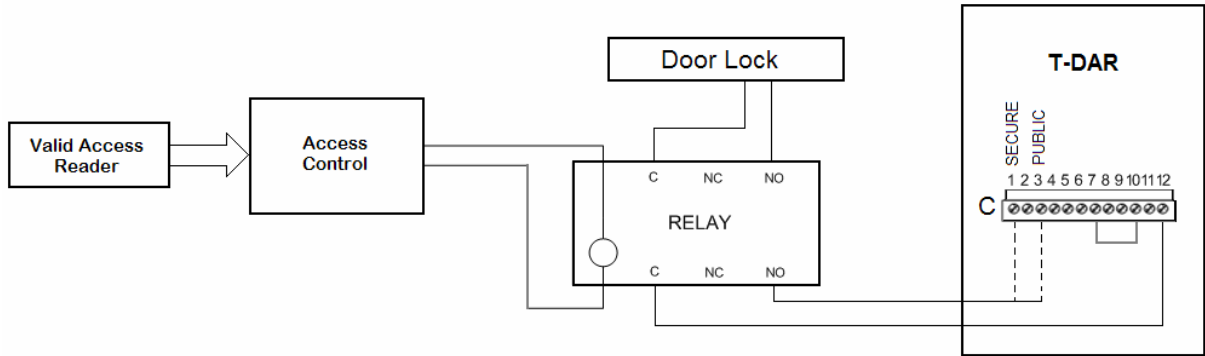

Public and Secure Valid Access Connections (Option 2)

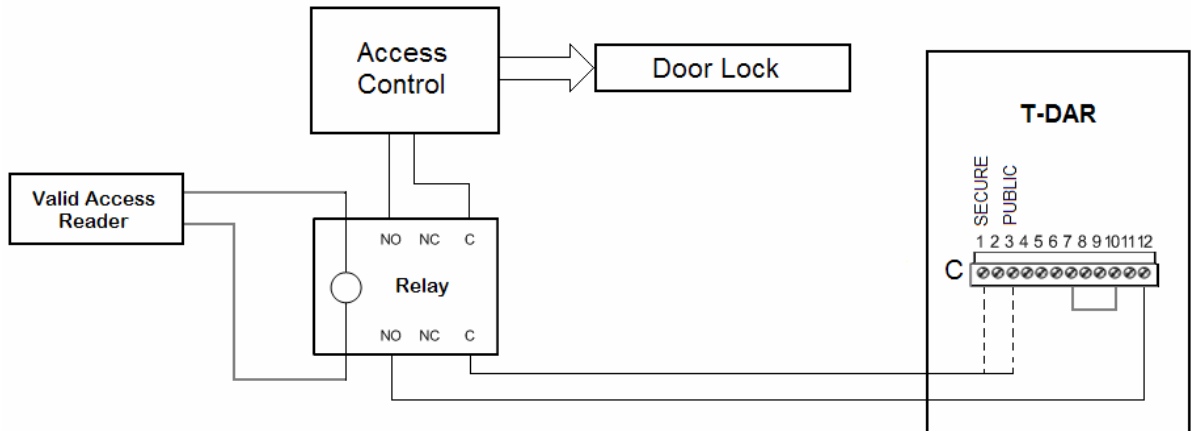

Door Position Sensor (Door Encoder)

A public Inward Swinging door must use an I100 Door Position Indicator. If an I100 Door Position Indicator is not used for public doors that swing into the field of view of the camera, erratic operation will result. The secure door does not require the use of a Door Position Indicator. The cable for connecting the sensor should be extended from the wall/frame and terminated into the unit. The cable is a straight through Ethernet (cat 5) cable terminated with an RJ-45 connector. The other end of the cable is then terminated as flying leads on the C portal connector as shown below.

Public Door Encoder Connection

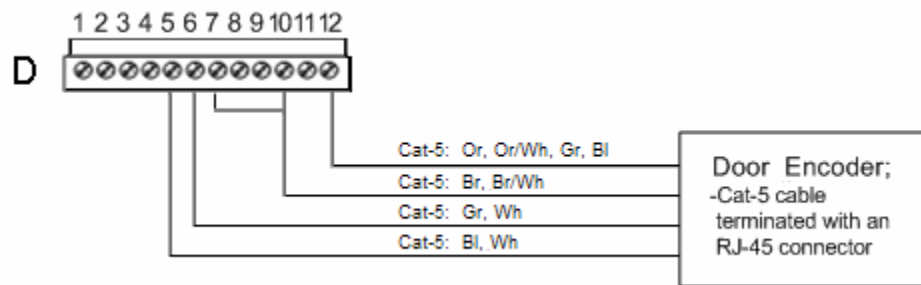

Annunciator Unit

The Annunciator Unit needs to be located at the security portal being monitored so that violations are immediately announced to the violator as well as the persons in the secure area. Install and terminate one Ethernet cable (straight through) on the Annunciator Unit, leading directly to the 'Annunc 1' connector on the T-DAR control unit.

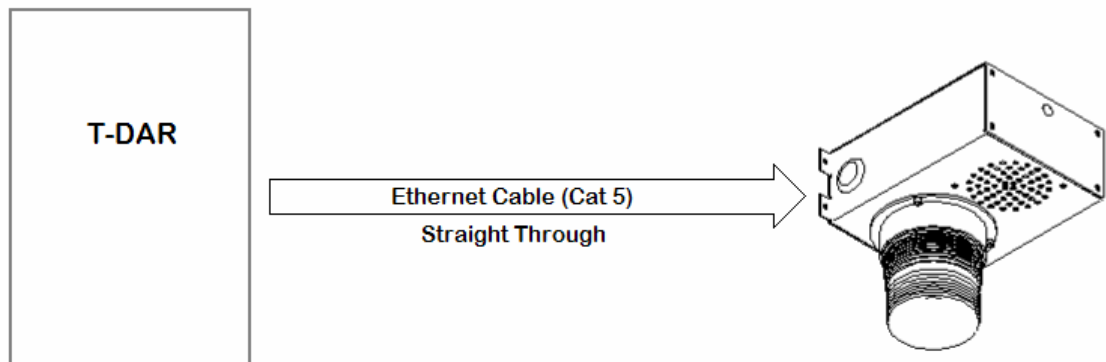

Supervisor Override (User Interface Bypass)

Supervisor override is input 1 on the T-DAR control box. When mantrap software is loaded onto a T-DAR control box, the supervisor override will allow multiple persons or object of any size to pass through the mantrap. At no time will both doors be allowed to open at the same time. If multiple persons are to proceed through the mantrap using the supervisor override, the public valid reader will still require a valid grant before the secure door is allowed to open. Anytime the supervisor override signal is given, the light will flash on the annunciator until the signal is released.

Method of Operation Using a Supervisor Override Switch

The supervisor override may be used momentarily or continually. To stop presently running annunciator alarms and all alarm output relays, press the override switch momentarily or continuously. Pressing the override switch momentarily will stop the T-DAR system from any present alarming, on all prior violations. In addition, this will reset the T-DAR unit to a non-alarming state, where the T-DAR unit does not know if there is zero, one, or multiple persons in the mantrap. As soon as the switch is released the T-DAR unit will alarm immediately when a violation is detected.

Pressing the supervisor override switch continuously will halt all annunciator and relay alarming until the switch is released. While the override switch is pressed, a valid public access grant will unlock the secure door, in all cases. Alternatively, a valid secure access grant will not unlock the secure door in every case. The annunciator light will continue to flash as long as the switch is pressed.

CONNECTION TO LAPTOP / LAN

To Configure the Host TCP/IP Connection

1. The factory set TCP/IP connection on the host computer is typically set to “automatic”. Changing these settings will establish a connection to the Newton Security Inc. TDAR, but may disconnect or even conflict with your current network system. Please check with your network administrator if you have any questions.
2. From the desktop right click “My Network Places” and select “Properties”. A new window will open, select “Local Area Connection” and click “Properties” from the new selection. A third window will open, select “Internet Protocol” (TCP-IP) and click its “Properties”.
3. You will see a selection box labeled “Use Following IP Address, select this option.
4. Enter the following information:
 - a. IP: 10.0.0.21 (unless the unit is .21, then use .22, etc)
 - b. Subnet: 255.0.0.0
 - c. Gateway 10.0.0.1
5. Apply these changes and return to the desktop. You may have to reboot your host computer before the changes take effect. The system will now connect using the **Configure Connection** option in the User Interface.

Install the Software

The Newton Security Inc. T-DAR System Software CD-ROM contains an installer for the user interface application and a loader program for the T-DAR Control Unit application. These applications are contained on disks, included with the T-DAR system. New systems are shipped with the T-DAR Control Unit application preinstalled. The included Control Unit install disk may be used for backup purposes.

User Interface (UI) Application

1. Insert the T-DAR Software CD-ROM into the host PC.
2. Press Start on the Task bar and select Run.
3. From the Run dialog box, type **d:\setup or**
4. Browse to the CD-ROM drive and execute setup.exe.
5. Follow the on-screen instructions.

User Interface Installation Tips

The Newton Security Inc. T-DAR System Software must be fully removed from the host computer before the new user interface software is installed. There can be only one Newton Security user interface installed on a computer, at one time. Failure to remove existing software will result in poor system performance.

Before removing existing Newton Security software, be sure that you have access to the setup (installation) software, for the user interface software that is to be uninstalled.

Before removing installed software, save the settings of the portals and mantraps that you have access to. Saving settings is explained in the User Interface section of this manual.

Before removing software, make a record of the user interface version and control box version of each mantrap or portal. Store these records for the T-DAR systems in an easily accessible location, on your PC and (if possible) next to each T-DAR control unit. This information may be required by future setup personnel.

T-DAR Control Unit Application

1. Connect the T-DAR Control Unit. Refer to *page 22*
2. Insert the T-DAR Software CD-ROM into the host PC.
3. Press Start on the Task bar and select Run.
4. From the Run dialog box, type **d¹:\update** **or**
5. If the system is connected via a serial cable instead of the normal Ethernet, browse to the CD-ROM drive and execute update.exe.
6. If the T-DAR controller is connected via Ethernet, browse to the CD-ROM drive and execute update.exe ###.###.###.###, substituting the #'s with the IP address of the vision system.
7. Follow the on-screen instructions.

After the software is loaded, the UI may be launched from the start menu on the host computer.

Start -> Programs -> Newton Security Inc -> T-DAR Mantrap

Once the system hardware is configured, the UI application is no longer needed and the T-DAR will run unaided.

IMPORTANT NOTE: There can only be one copy of the T-DAR UI installed on a computer at a time. As an example, T-DAR Tailgate Detection software must be removed before T-DAR Mantrap software is installed. Failure to do so may result in inconsistent behavior.

¹ Substitute **d** with your host computer's CD-ROM drive letter

Configure Connection

Selecting Configure Connection from the menu opens the dialog box to specify connection type, IP address and connection preference.



Figure 18 - Configure Connection

Connecting via Ethernet

1. Serial number and factory-set IP address of each vision system is printed on the inside lower corner of the door of the unit, in the following format:

SN: CB210MT0100110 IP: 10.3.2.21

2. The IP address in the above label is 10.3.2.21
3. If the IP address in the UI matches the unit, skip to step 7
4. Select **Connection** then **Configure Connection** from the application's menu bar.
5. Select **Ethernet, IP address** from the **Configure Connection** dialog.
6. Enter either the pre-configured IP address in the field next to **Ethernet, IP address** or enter a new IP address that is compatible with the network.
7. Note: If the IP address of the vision system is changed, the information printed on the unit will no longer be valid.
8. Select **Connection** then **Connect** from the menu bar.
9. A connection via Ethernet should establish.

Configuring the T-DAR

The T-DAR user interface (UI) is used to set-up and optimize the detection performance of the system. The following instructions provide guidelines that will enable the installer to quickly and effectively place the T-DAR system in service.

Viewing Images

The installer should select the Show Camera Views view from the monitor page. This will display a “four view” image on the CCTV monitor showing the tracking image, event camera video, and tracking camera views ‘a’ (1) and ‘b’ (2) from a single camera head. Using this image, the installer is able to clearly see what the system is viewing in real time. Images from the secure door or the public door may be shown, independently.

Calibration

After the unit has been installed and the UI is connected to the unit, a calibration must be performed. The purpose of the calibration is to ‘teach’ the system what the area of detection looks like when the area is empty of people. The secure camera head (camera 1) and the public camera head (camera 2) will both need to be calibrated. Objects that are not normally in the scene such as carts and parcels should be removed before the calibration is performed. This clean calibration will then allow the system to recognize objects introduced into the scene and track them accordingly while ignoring those objects that are normal to the scene.

Inward Swinging Public Door

The following describes the process for performing calibration when an inward swinging door sensor (door encoder) is used. An inward swinging door swings under the view of the camera head. A door sensor is not required on the secure door of the mantrap. After the door sensor has been terminated at the Control Unit, it should be powered up and tested. On the monitor page, select I/O Display and choose Public Door from the drop down menu. Test the door sensor by slowly moving the arm back and forth. This should result in a change in the sensor value shown at the bottom of the CCTV monitor display. If no change occurs in the current sensor values, as the door is swung, check to be sure the wiring is terminated at the proper inputs.

To calibrate the door, follow the instructions on the screen when the Calibration button is clicked. Be sure that ‘Inward Swinging’ is checked on the Initial Setup tab, for the public door. ‘Inward Swinging’ should be unchecked for the secure door. After calibration, verify that the tracking image is calibrated successfully (black image). Verify that the door is removed from the image as it is swung through its full range of motion from open to closed. The door should be blacked out at every possible position.

Testing the Units

The units should be periodically tested to ensure that they are functioning properly. This can be easily accomplished by having two persons walk into the mantrap through the public door. This should generate a local and remote alarm. The local alarm should say “only one person at a time allowed through door”. If an alarm is not correctly annunciated (i.e. no audible message), cycle the power and repeat the above steps. If the system still does not operate correctly, see the annunciator portion of the manual. If the system still does not respond, call Newton Security Inc. or your integrator for additional support.

Capturing Events

Alarm event video is captured and stored in volatile memory on the system. There is no onboard persistent storage of alarm video information; if the system power is interrupted, all stored video will be lost. Use of an external DVR system is recommended if permanent storage of alarm events is required.

Configuration and Setup of the T-DAR Software

Components Needed for Setup

Utilizing the T-DAR user interface, connect to the T-DAR system and follow the steps outlined below to configure the T-DAR system. To conduct the set-up operation, the following items will be needed:

- An Ethernet-capable computer running the T-DAR user interface software
- A video monitor or television with video input
- The T-DAR controller software and camera calibration CD's that came with the system
- All associated cables and connectors for connecting devices such as computers, Ethernet hubs, and monitors to the T-DAR controller (Note: a cross-over cable may be used for direct PC to Control Unit, communication)

Setup Process

Once the components are properly connected, the T-DAR system may be powered on. The following steps will complete the set-up process.

1. Connect to the T-DAR controller using the IP address on the label, located on the inside of the controller door. The lower left corner of the user interface displays the connection status. If a connection can not be made, please refer to the troubleshooting section for further assistance.
2. On the monitor tab in the user interface, change the Display Demo to 'Show camera views'. View the public door Camera Head by selecting 'Public Door' from the drop down menu.

3. Observe the bottom two images (videos) on the monitor. If any video signals are missing, or if any of the signals are rolling or noisy, please refer to the troubleshooting section for further assistance.
4. Change to the secure door Camera Head using the pull down menu and repeat step three.
5. In the user interface, change tabs to the Setup I/O tab
6. Set the time and date on the controller
7. Verify that all of the alarm devices are enabled (checked) and that the Alarm Timeout is at least 5 seconds.
8. Click on the initial set-up page and draw a green line at the base of the door jam for the secure door. This will automatically set the proper regions of interest for scanning. Select Public Door from the drop down menu and perform this same step.
9. The system should now be operating and ready for tests. (See testing the system Pg. 51)

USER INTERFACE

Detailed Information

About the T-DAR User Interface Software

The T-DAR User Interface (UI) software consists of seven tabbed pages labeled as follows; Initial Set-up, Monitor, Installer I/O, Installer Camera Settings, Setup I/O, System Log, and Advanced. The User Interface is navigated by a series of tabs and menus. The tabs control the configuration, setup and monitoring of the system. The menus contain options for configuring connections, saving/loading settings, and performing advanced changes to the system.

Tab Pages

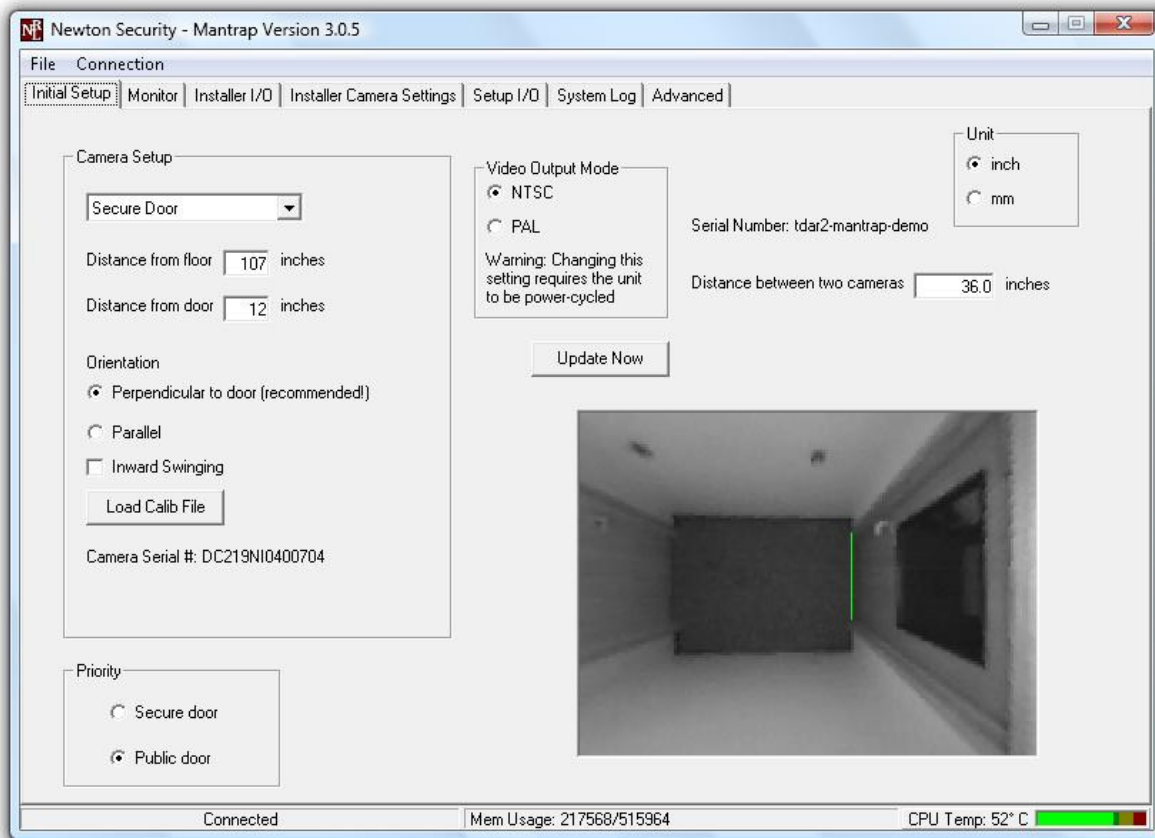

Figure 20 – Tab Pages

File Menu

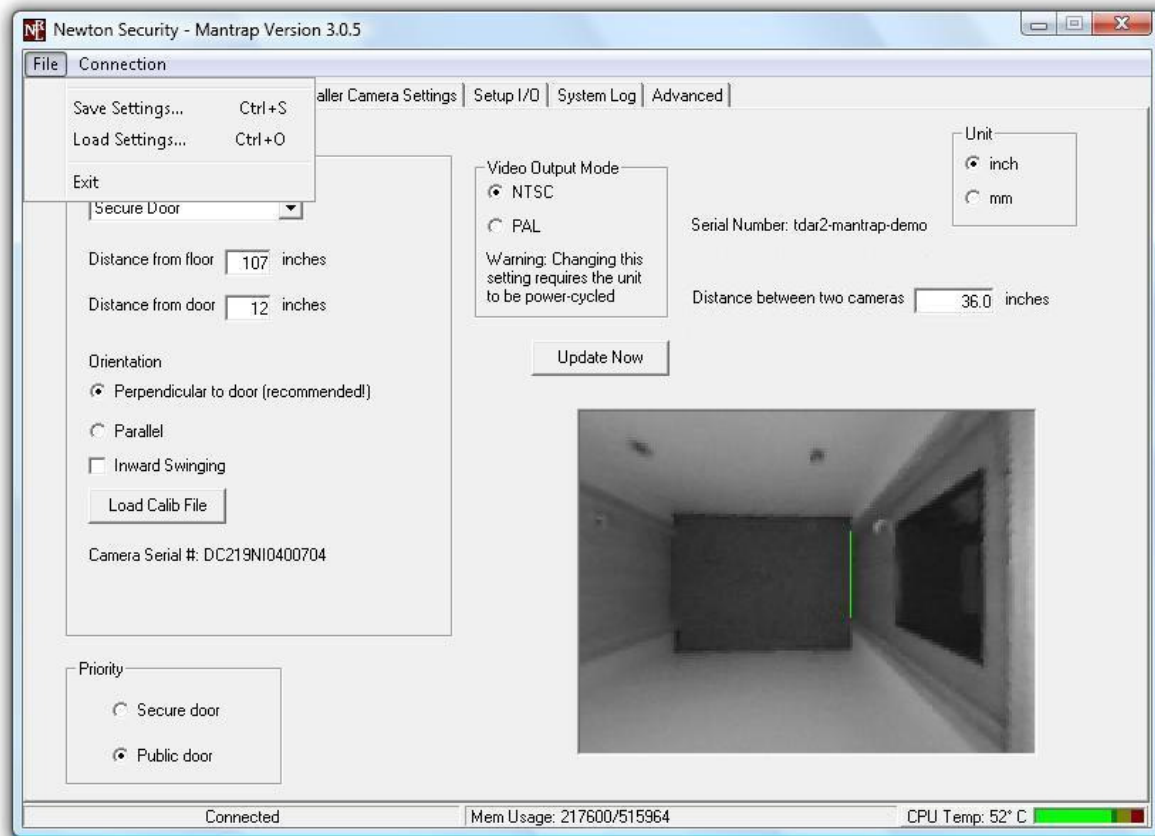

Figure 21 – File Tab

Selecting **FILE** from the menu opens a window that allows the options for saving and restoring settings. These settings can be stored in another computer. In the event of having to restore the software, any configuration adjustments can be recalled from this file.

Save Settings

The **Save Settings** option compiles all the user configurable settings into a file to be saved for system back-up. This file has the “.nlc” file extension. This file should be saved to the computer designated to be host for the User Interface. A copy of multiple T-DAR system settings files should be stored and maintained centrally. It is recommended that the user defined logical names be assigned to the files, such as “Door 569.nlc” to avoid confusion.

Load Settings

Use **Load Settings** to perform a system restore from the file saved by using the **Save Settings** feature. A window will open asking the operator to specify the file location for this unit’s settings. Choose the location of the desired file and click **OK**

Exit

Clicking the Exit button closes the User Interface. The T-DAR will continue to run and perform security inspections even with this interface disabled. Settings and parameters that have been changed with the User Interface will persist while disconnected. The Host computer will be completely removed from and have no communications with the operating unit.

Connection Menu

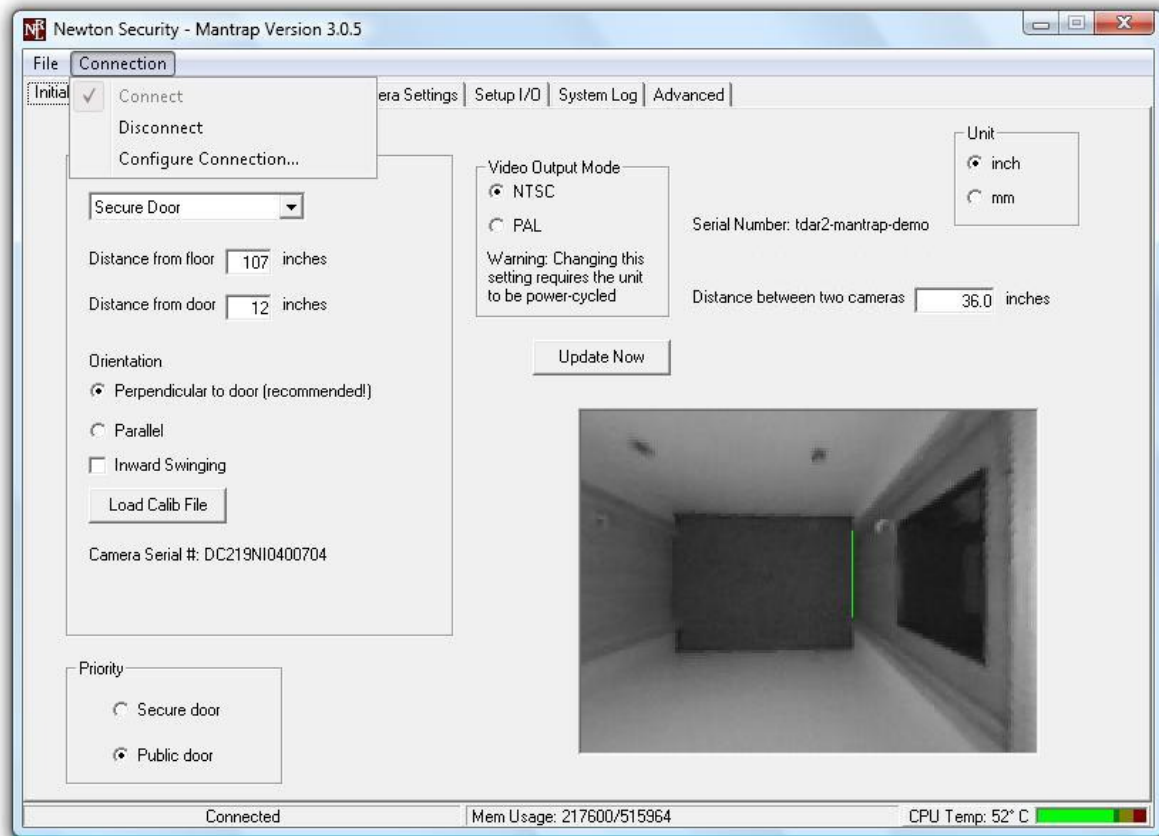

Figure 22 – Connection

Connection

Connect establishes communication between the UI application and the T-DAR hardware. A connection must be established before proceeding to the run menu or before performing subsequent UI operations. If the T-DAR IP has been previously configured, selecting **Connect** from the menu will enable the User Interface. Once enabled, changes may be made to the connected unit.

Disconnect

Disconnect may be used to close the connection with the T-DAR unit and disable the User Interface. The ability to make changes to the unit ceases, but the User Interface remains open on the Host computer. This is a convenient method to troubleshoot connectivity problem.

Configure Connection

This selection allows for adjustment as to how the T-DAR connects to the host computer. Connections may be made via addressable IP or serial connection. The option for **Always Connect on Start Up** is also provided.

Debug Tab:

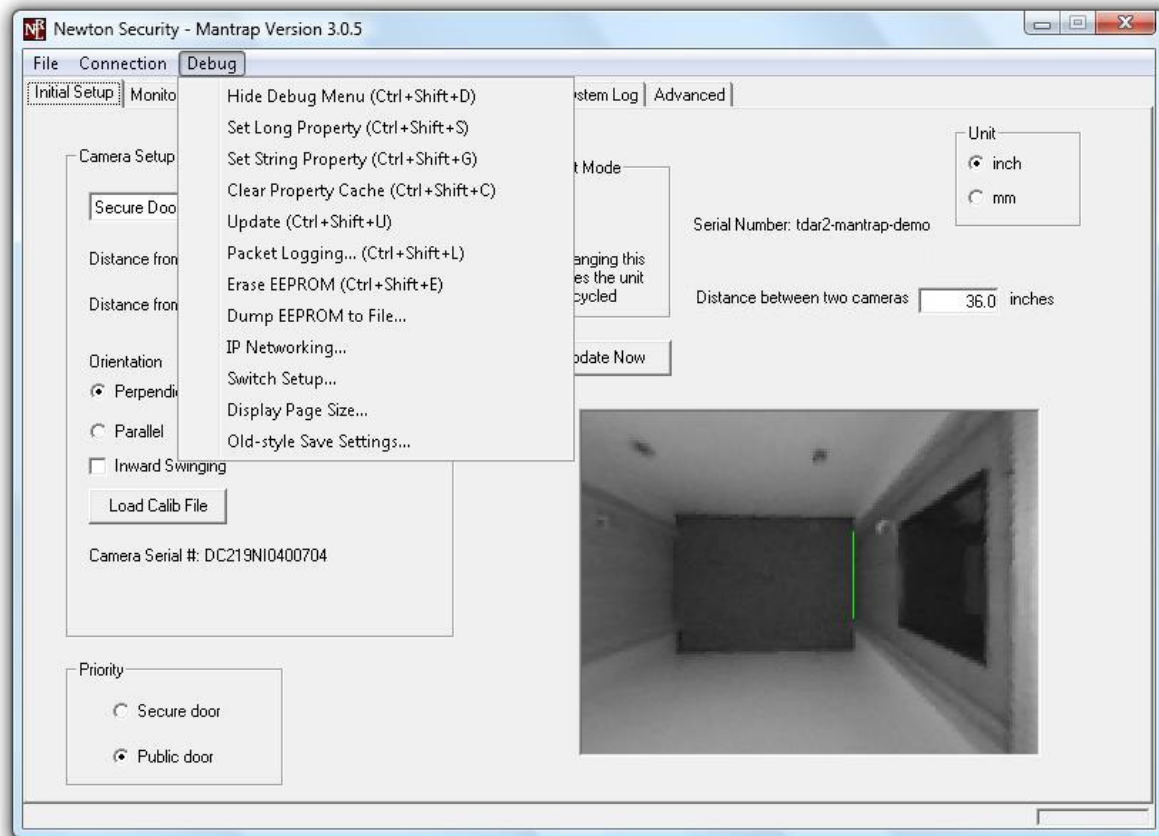

Figure 23 - DeBug Tab

Hide Debug Menu

This allows you to hide the Debug menu. The Debug menu is not for general use, it is designed to be used by the system Admin to troubleshoot the system. Do not make any changes using this menu if you have not been properly trained. Unexpected behavior by the T-DAR system may result if items on this menu are not properly utilized.

Set long and String properties

The **Set long and String properties** allows you to manually enter values for properties that are not accessible with GUI. (Consult manufacturer for commands)

Clear property Cache

This clears all long and string properties stored in temp memory

Updates

The **Update** function is currently disabled.

Packet Logging

The **packet logging** function logs all data, and commands sent from UI.

Erase EEPROM

This function erases all current setting and restore unit back to factory defaults.

Dump EEPROM

This feature allows you to save the current EEPROM setting to a file, for technical analyst/troubling support from manufacturer.

IP Networking

IP Networking allows you to change the IP address, subnet mask, and gateway that you unit uses to connect to your company internal network.

Switch Setup

The **Switch Setup** function is currently disabled.

Display Page Size

The **Display Screen size** function shows screen resolution.

Old-Style saves settings

This is another way to save settings to a file.

Initial Set-up

The initial Set-up tab is the most important tab in the UI. Here the technician will enter the camera height, distance from floor, distance from door, distance between cameras, orientation of cameras, load camera calibrations, and draw the green lines (lines of demarcation). The green lines are drawn for each door to automatically set-up the scanning regions. The initial setup tab contains the serial number of the T-DAR control unit. Until all of the fields are properly filled out on this tab you will not be able to move to some other tabs in the UI to complete the setup.

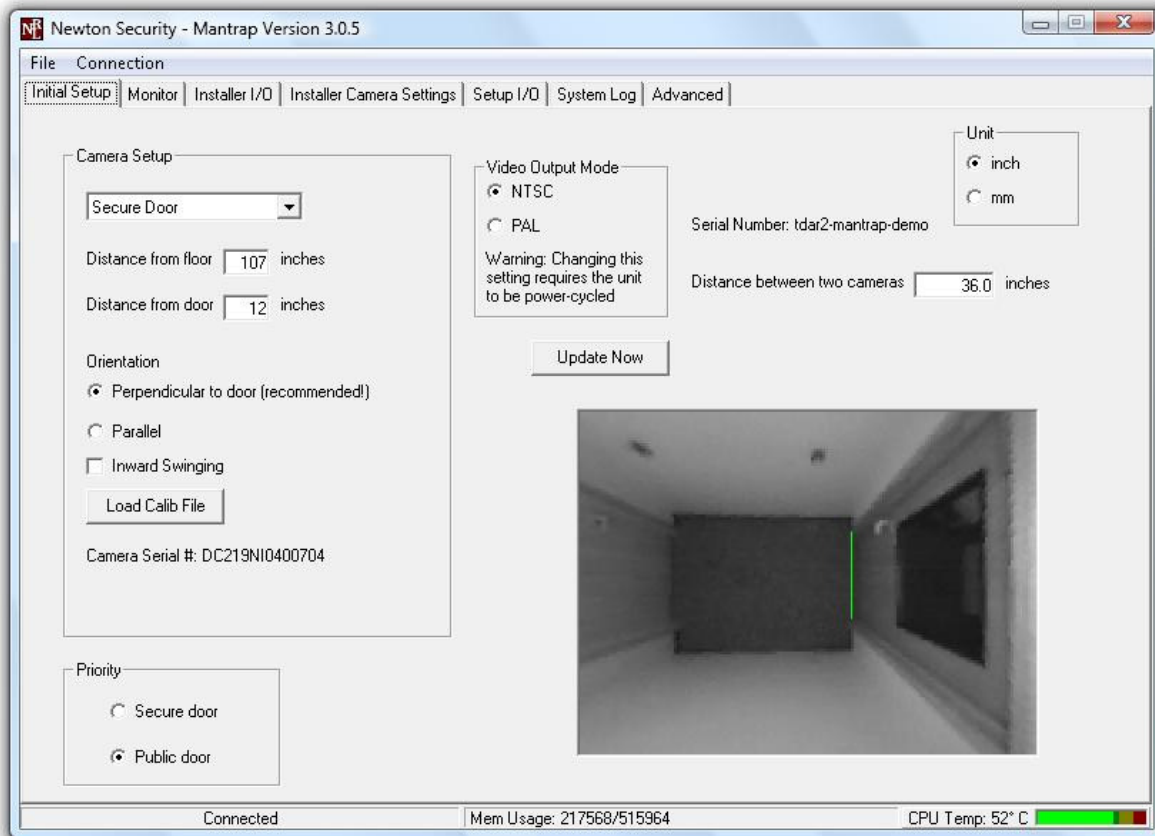

Figure 24 - Initial Set-Up Tab

Camera set-up

Here the technician will input various distances that the cameras are placed away from the door and the floor. Choose the orientation of the mantrap cameras and load the calibration files. There may be a field for 'Distance between two cameras (par)'; set this to zero. (See stereo head placement chart for optimal placement)

Video modes

Here the technician chooses NTSC or PAL depending on the type of camera and video system they are using

Green Line

With the crosshair draw a green line at the base of each door of the mantrap. Select the individual doors from the dropdown menu and select **Update Now**. This will automatically set up the regions for scanning.

Monitor Tab

The Monitor page consists of a various menus that allow the user to change between cameras and views that will be displayed on the CCTV monitor. A list of camera views is available for selection by way of radio buttons. Also on this page is an Alarm Reset button for the annunciator, as well as mantrap event statistics. The statistics may be reset using the Reset Event Statistics button on the Setup I/O page. There are no installer configurable items on this page.



Figure 25 – Monitor Tab

Display

The **Display** section of this page controls what video displays on the monitor. The settings are unique to the door being monitored. The output chosen will be the video that is recorded during a security event.

Normal	Event video out during alarm only
Show Camera Views;	Camera Head images, tracking image and event video
Show Tracking Image	Displays tracking image
Show Tracking Camera 1	Camera Head image a (1)
Show Tracking Camera 2	Camera Head image b (2)
Show Event Camera	Event Camera video (ported for two cameras)
Show I/O	Displays the status screen for I/O diagnostics

Alarm and Events

A button for manually resetting the alarm is available in the UI. Clicking **Reset Alarm** will clear an alarming security event and return the system to its normal monitoring mode.

The **Events** counter is a running log of the security scenarios being monitored by the T-DAR. Events are characterized by access events, door cycles, and security violation types.

Event Camera

Two check boxes are available for changing the properties of the event camera view in the normal display mode. These are as described below:

- Full screen mode allows the user to select a full sized image for event video display. Unselecting this feature will cause a quarter-screen image to be displayed instead.
- Show Live Feed mode allows the user to display live video from the event camera until an alarm occurs, at which time the event playback will occur. Once event playback is complete, the image will return to a live format. Unselecting this feature will cause the screen to be blank until event playback occurs.

Setup I/O

The Setup I/O page consists of an Alarm section, Playback section, and a Time section. Resetting Event Statistics and changing the Administrator Password are also available. These items are detailed below.

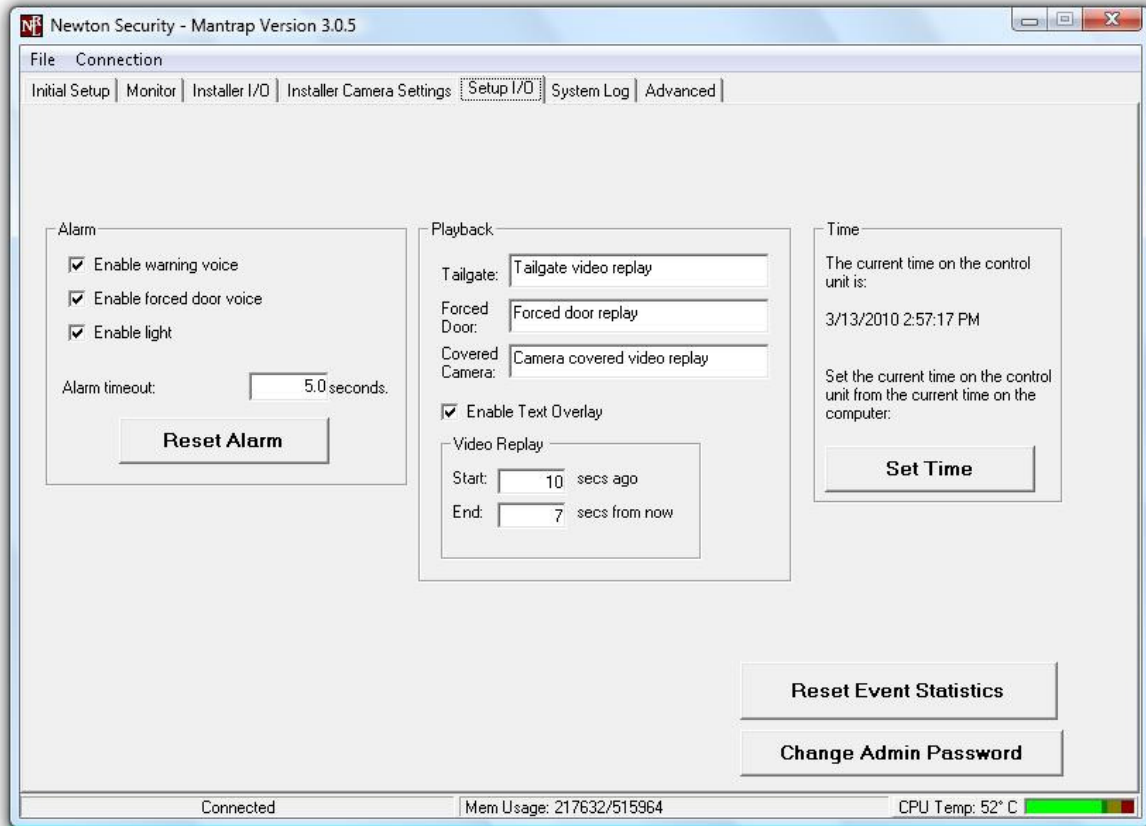

Figure 26 - Set-up I/O

Alarm

The alarm section consists of check boxes that allow the user to disable all of the various alarm enunciation provided by the Annunciator Unit. There is also an Alarm Timeout box that defines how long an alarm will annunciate for before resetting. Setting this value to zero causes the unit to be in manual reset mode only. Below the Alarm Timeout is a Reset Alarm button that resets the T-DAR alarm when clicked.

Playback

The Playback section lists the three types of alarms that will cause the T-DAR system to generate an event video replay. Next to each of these titles is a text box where the user can enter specific text that will be displayed over the event playback video. Additionally, there is a check-box that is used to enable text overlay of the user specified text as opposed to the default text as set by the manufacturer.

Video Replay

The Video Replay section allows the user to determine the length of the event video replay image clip that is displayed by the system. The Start time defines how long *before* the actual alarm is received that replay starts from, and the END time determines how long *after* the alarm was received the video is recorded.

Time

The Time section allows the user to set the time that is maintained in the controller. This time stamp is also displayed in all event video images. Clicking the Set Time button will set the time on the control unit to that of the PC running the User Interface. It should be noted that daylight savings time corrections must be performed manually.

Reset Event Statistics

The Reset Event Statistics is used to reset the statistics located on the Monitor page.

Change Admin Password

The admin password is the second highest level of access available to users. This allows access to the Monitor, Setup I/O, and Setup View tabs of the system. To configure the password, the button is clicked and then a password is typed either on the on-screen keyboard or on the host computer keyboard. If a mistake is made, use the backspace key to remove characters one by one, or the clear key to clear all of the characters simultaneously. Once the password is entered, press the OK button to make password permanent. If the password is lost, contact the installers of this T-DAR system or Newton Security, Inc.

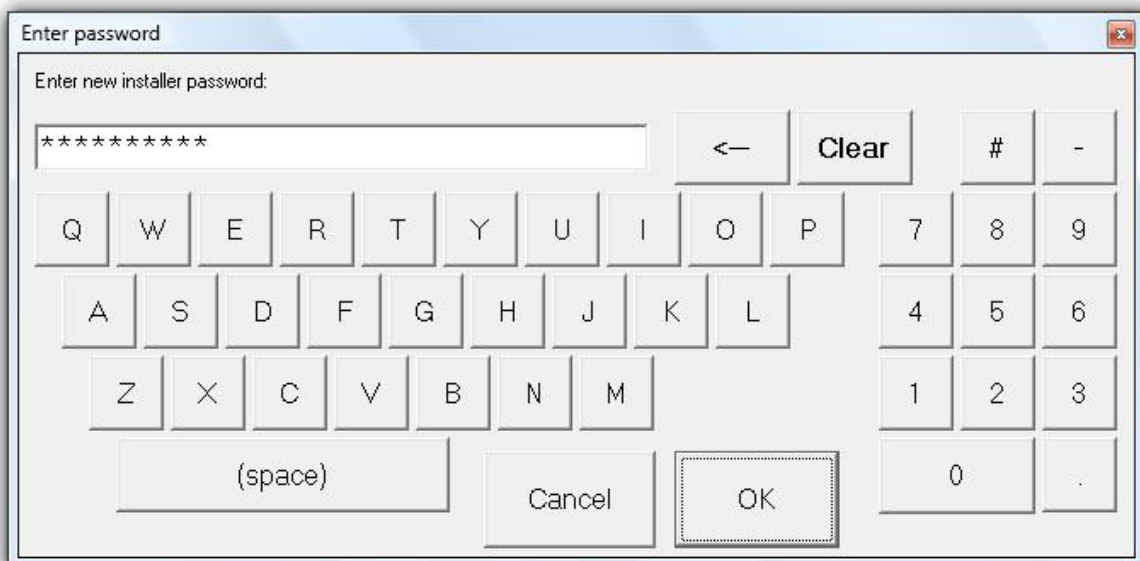

Installer Camera Settings

The Installer Camera Settings page consists of a pull-down, an Image Type section, an Update Now button, a Viewing Window, a Physical Setup section, a Sensitivity Section, and a Configuration Section. These are detailed below:

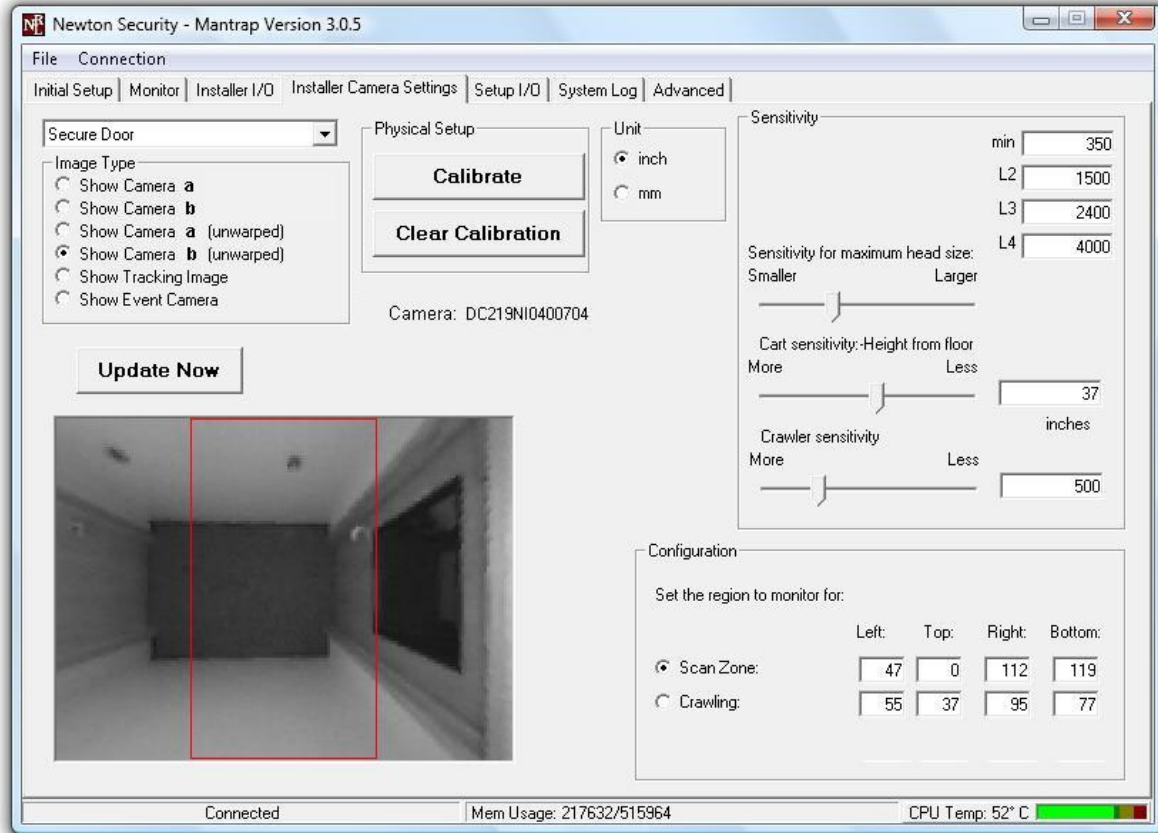

Figure 27 - Installer Camera Settings

Image Type

The image type section is used to select what camera is viewed in the image below. Various images can be selected using the associated radio buttons. All mantrap cameras, Secure a, Secure b, Public a, and Public b may be shown individually.

Update Now

The update now button updates the image in the Viewing Window. Updating affects the viewing window only.

Viewing Window

The Viewing Window displays the images selected using the Image Type section and displays the scan regions outlined with red boxes. The scan regions outline the areas of concern for the T-DAR system; the outlying areas are ignored. The Viewing Window provides modification of the scan regions by dragging and dropping with a pointer, directly on the image (this modification will update the configuration section).

To draw a region (red box) in the Viewing Window, the image displayed must be one of the two unwarped images. Position the mouse pointer over the top left corner of the area you want to draw the box around. Click and hold the left mouse button and drag the pointer to the location that sets the “red box” to the appropriate size. Changing the region will open a confirmation window, asking if the change is valid. To erase a region from the Viewing Window, click anywhere in the window.

Configuration

The configuration section is used to define the regions of interest within the scene that are monitored for tracking activity. The regions are selected by clicking on the adjacent radio button, and are then defined by drawing a box in the Viewing Window with the mouse pointer. Additionally, the values may be entered in the numeric box adjacent to each region. See the section entitled Viewing Window, above, for more information on adjusting region areas.

Scan Zone

The region of interest for scanning should be large enough, that when the regions of both Camera Heads are combined, the entire mantrap is in view. When switching between the Secure Camera and the Public Camera, update the image. The sides of the scan zones extending up the walls of the mantrap (Top: and Bottom:) are typically set to their extreme values, 0 and 119. The side of the box extending toward the corresponding door should extend slightly three quarters of the way up the door. The side of the box that is further from the corresponding door should extend far enough (from the door) to cover three quarters of the mantrap floor.

Crawling

The region of interest for crawling should be wider than the door, extending up the walls approximately two feet. The Crawling region should start at the base of the door and extend into the mantrap about three feet from the door.

Entry from public/Exit to public

If your user interface contains regions for ‘Entry from public side’ and ‘Exit to public side’, set these values to zero. They are not used in the T-DAR Mantrap system. For these regions, set all eight fields to zero.

Physical Setup

The physical setup section consists of two buttons used to control the camera calibration process. The Calibrate button is used to teach the system about the scene that is being monitored. When the system has learned the environment, the tracking image will become stable and black unless objects are detected. The Clear Calibration button is used to expose the raw tracking image. Using this raw tracking image, the installer can determine the effect of various objects in the field of view on the tracking system. Also, refer to the Clear Calibration section for information on clearing calibration when using a Door Position Sensor. A door position sensor is used on the public door only and is not required for doors that do not swing under the camera head (outward swinging).

*****IMPORTANT NOTE*****

Calibrations must be performed when the scene is completely stable. The scene must be stable for several seconds after the button is clicked, until the image stabilizes at a black level.

Sensitivity

The sensitivity section contains slider bars for maximum head size, cart sensitivity, and crawler sensitivity. Adjacent to each of these sliders is a numeric box that shows the numeric equivalent for the slide position. The values may be adjusted by either manipulating the slider or through direct entry of the values in the numeric box. The slider bars are detailed as follows:

About Settings:

The use of stereo machine vision analysis allows the system to assign a fairly constant numeric value to an object regardless of how far or close the object is to the camera lens. This number represents the amount of pixels the system needs to see to place a cross-hair on an object

Minimum Head Size

The minimum head size field (above L2, L3, and L4) controls the value (in pixel area) that determines the smallest object that can be called a head without incorrectly identifying carried objects as a head. To stop a small object from being detected as the head of a person, set the minimum head size (in pixel area) to be larger than this small object. Setting this value too small may cause the system to perceive a carried object as the head of a person. Setting this value too large will cause the system to ignore persons who's heads do not meet this minimum requirement. If the value for minimum head size is set to low, small objects can be incorrectly considered the head of a person. A standard value is 350.

The monitor output can be configured to show the number of persons detected under a camera head by displaying a "Head Count" value and showing a cross over every object that is considered the head of a person. Viewing this output is accomplished by using the 'Show Camera Views' option from the monitor tab, which also provides a tracking image. The public door or the secure door may be individually selected for monitoring.

L2, L3, and L4

The values L2, L3, and L4 represent various horizontal cross sections of a person's body at different heights, measured from the top of the head. The value L2 corresponds to the area (in pixels) one inch down from the top of a persons head. The value L3 corresponds to the area two inches down from the top of a persons head. The final value L4 corresponds to the area nine inches down from the top of a persons head (shoulder area roughly). Typical values for these fields are 2500, 3200, and 3800 (units are in pixels).

Maximum Head Size

The maximum head size slider controls the value that determines the largest object that can be called a head without allowing more than one person to proceed through the portal. The head of a person may be incorrectly detected as two persons because of large hair, a hat, or other types of clothing. A small amount of trial and error may be necessary to account for items such as hats and very large hair styles, as well as the use of hooded parkas.

The monitor output can be configured to show the number of persons detected under a camera head by displaying a “Head Count” value and showing a cross over every object that is considered the head of a person. Viewing this output is accomplished by using the ‘Show Camera Views’ option from the monitor tab, which also provides dynamic tracking. Either the public door or the secure door may be selected for this monitoring. Enlarging the maximum head size will increase the value, in pixel area, that is allowed for a single head. This will stop false alarming on heads that would otherwise be seen as multiple people. Setting this value too large will allow multiple people to tailgate.

Cart Sensitivity

The cart sensitivity slider controls the maximum height of cart that will be allowed to pass through the mantrap. Stated another way the Cart Sensitivity sets a height above the floor in which everything beneath will be ignored, except persons. An object below this height will be considered a cart when it is in close proximity to a person. When not in close proximity to a person, an object below this height will be considered a crawler when it exceeds (in pixel area) the value set for Crawler Sensitivity.

Crawler Sensitivity

The crawler sensitivity controls the value that determines the size a specific object must be larger than to be called a crawler (crawling person). An object will be considered a crawler when it resides inside of the crawling region, is larger than the Crawler value specified (in pixel area), and is not in close proximity to a person. An object that is higher than the Cart Sensitivity value will not be considered a crawler. An object that is next to a person will not be considered a crawler. Objects that are considered crawlers will cause an alarm. A typical value for Crawler Sensitivity is 500.

Installer I/O

The Installer tabs are for configuring the interface with the other components of the installed security system. Provisions for configuring the Outputs, Door Setup and Sensitivity are accessed from these pages. These pages can be password protected for Installer and System Administrators use only.

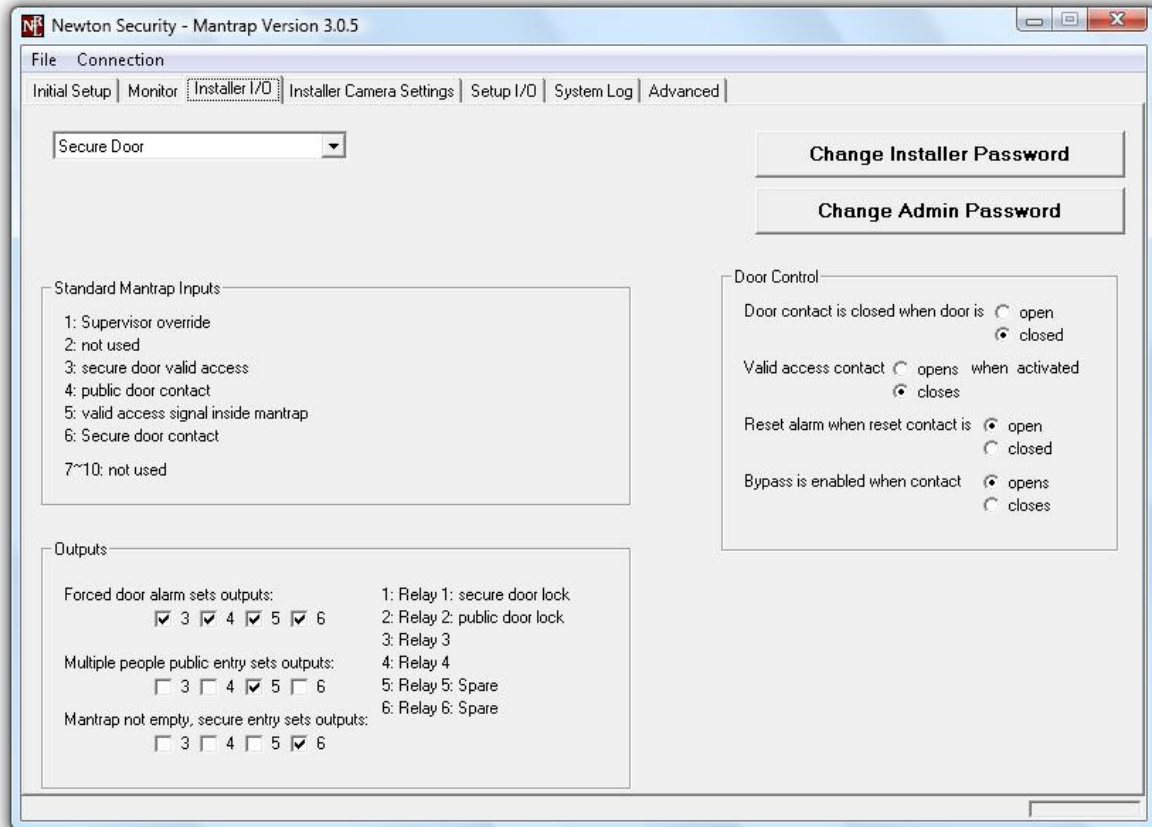

Figure 28 - Installer I/O

Door Control

The configurable options of the **Door Control** section allow for adapting T-DAR to the existing peripherals to correctly trigger the unit. The logic state for these devices, as used by the T-DAR, is selected by clicking the check box that reflects the installation. For example, if the door contact passes continuity when the door is closed the door contact is said to be **closed** when the door is closed. The same logic is true for the **Access Contact** and the **Alarm Reset**. If there is some question about the setting here, use the following steps to diagnose the issue:

Door Contact

- On the monitor tab, observe the count for door opens (reset the counts on the setup I/O page if necessary).
- Open and hold the door.
- If the door opens count increments by one, the switch is set correctly.
- If the door open count does not increment, close the door.
- If the door open count increments now, then the switch is set incorrectly.
 - If the count does not ever change, switch the display mode to Show I/O and observe the display of the I/O function on the screen. I/O assignments can be seen in Figure XX, page XX.
 - If no changes are observed on the screen during testing, verify wiring of device and controller.
- Set the switch correctly and re-test.

Valid Access Contact

- On the monitor tab, observe the count for Valid Access Contact (reset the counts on the setup I/O page if necessary).
- Perform a Public (or Secure) Valid Access Grant.
- If the Valid Access Contact count increments by one immediately, the switch is set correctly.
- If the Valid Access Contact count does not increment immediately, but takes a second or more to increment, the switch is set incorrectly.
 - If the count does not ever change, switch the display mode to Show I/O and observe the display of the I/O function on the screen
 - If no changes are observed on the screen during testing, verify wiring of device and controller.
- Set the switch correctly and re-test.

Outputs

There are six relays on a CB-210 for connecting signals from the T-DAR. The first relay is for the secure door lock, **Relay 1A** and **Relay 1B**. The second relay is for the public door lock, **Relay 2A** and **Relay 2B**. Relays four through six are for the tailgate alarm and forced door alarm. Activating the relay is caused by enabling the selected relay number to make contact when an alarm event is present.

For example selecting **Forced door alarm sets outputs** check box 4, enables **Relay 4** to close when either the public or secure door is forced open. Likewise, when **Multiple people public entry** check box 5 is checked, **Relay 5** will close when tailgating occurs.

Setting triggering events for both doors independently is not possible. Otherwise, any combination of relays and triggering events may be selected. There is no specification as to how the relays are to be implemented. Regardless of whatever the control situation dictates there are three ways to close any of the relays.

Change Administrator Password

Use the same process as changing **Installer Password**. If the administrator password becomes lost contact the T-DAR system installer or Newton Security, Inc.

Change Installer Password

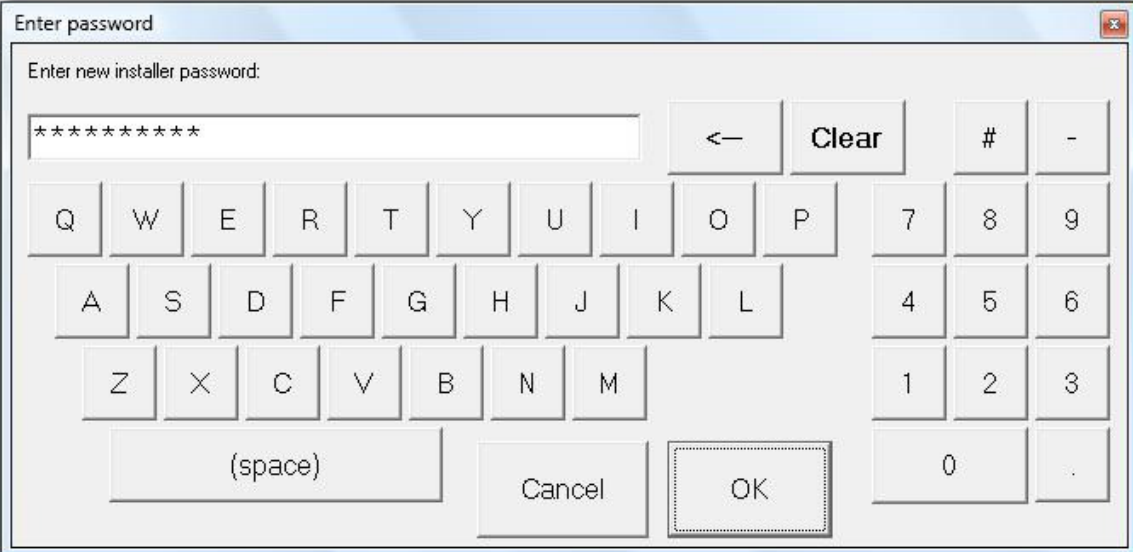

The image shows a software dialog box titled "Enter password". Inside the dialog, there is a text input field labeled "Enter new installer password:" containing ten asterisks. To the right of the input field are three buttons: a left-pointing arrow, a "Clear" button, and a "# -" button. Below the input field is a virtual keyboard with three rows of letters: the first row contains Q, W, E, R, T, Y, U, I, O, P; the second row contains A, S, D, F, G, H, J, K, L; and the third row contains Z, X, C, V, B, N, M. To the right of the letters are three columns of numbers: 7, 8, 9; 4, 5, 6; and 1, 2, 3. At the bottom of the keyboard area are four buttons: "(space)", "Cancel", "OK", and "0 .". The "OK" button is highlighted with a dotted border.

Figure 29 - Installer Password

System Log

This tab allows you to see the activity of the system, when doors open and close, what alarms have been active and what inputs and outputs have been triggered.

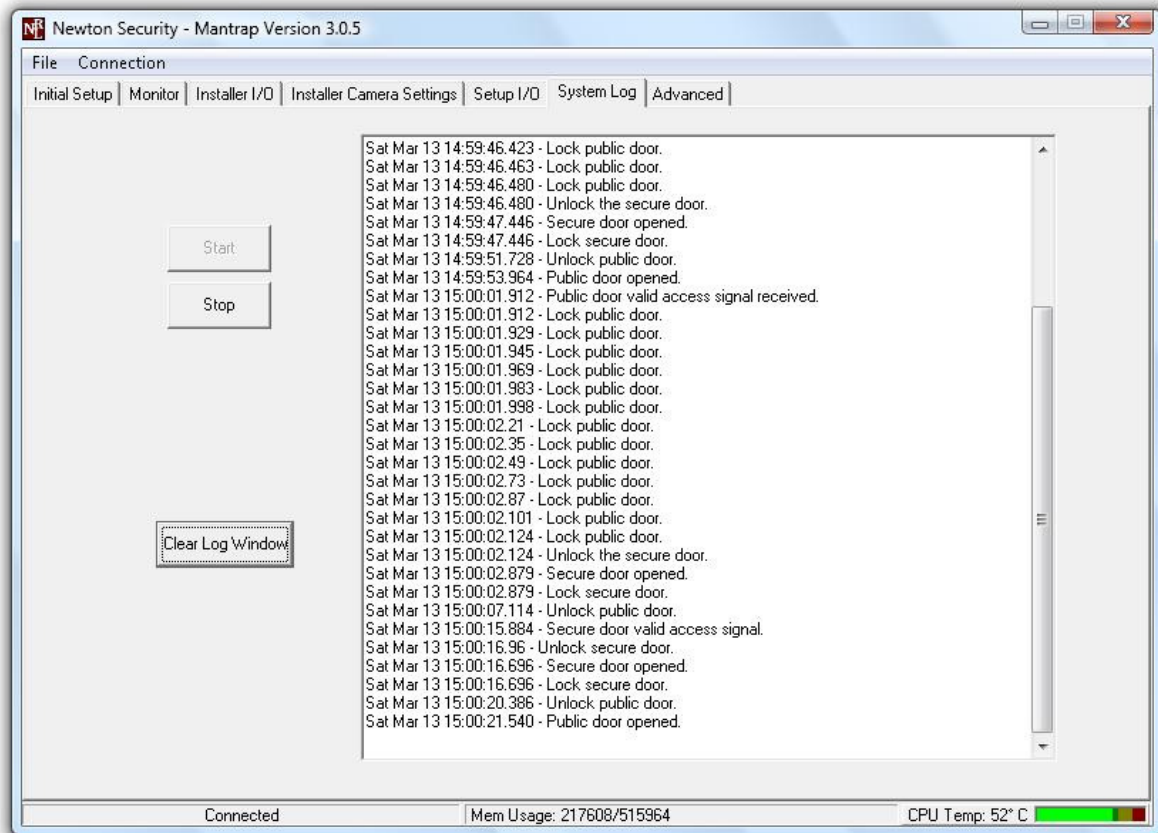

Figure 30- System Log

Advanced Tab

The Advance page consists of a number of user definable options that can override several of the standard controls of critical system functions detailed in previous tabs. These items should only be adjusted at the direction of qualified Newton Security Personnel.

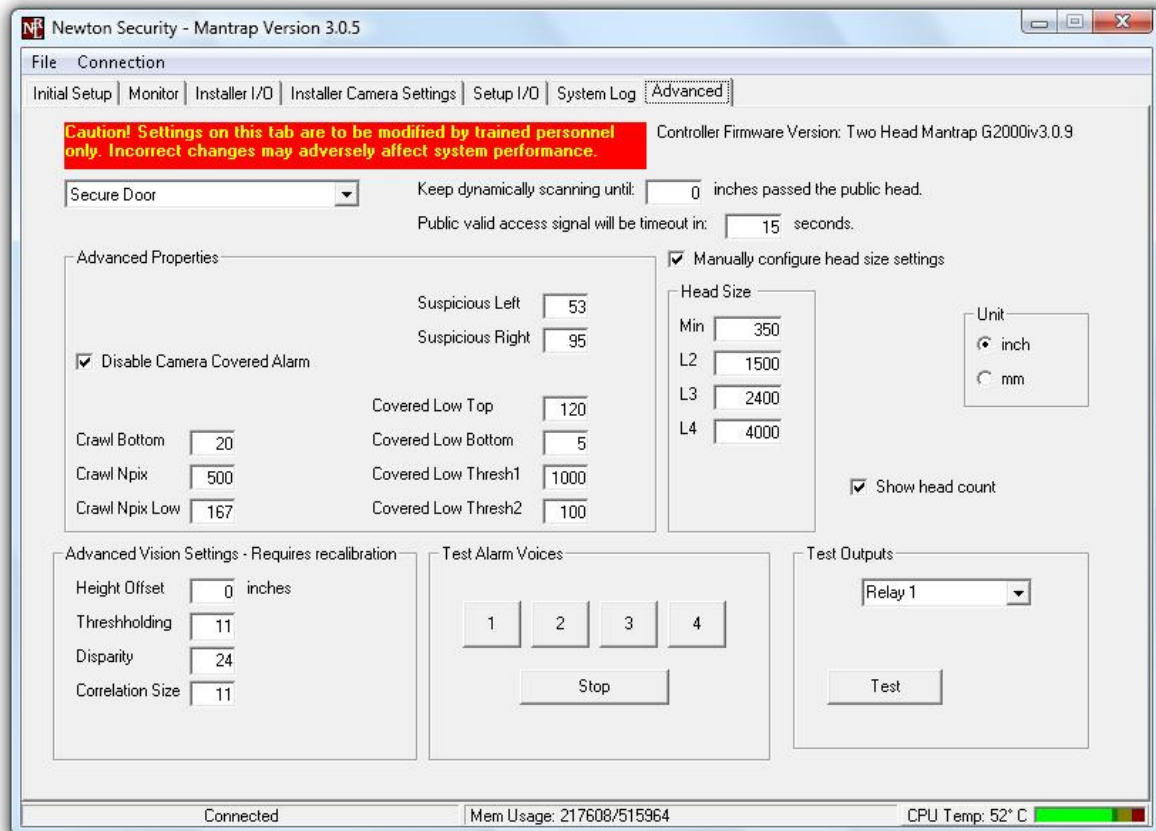
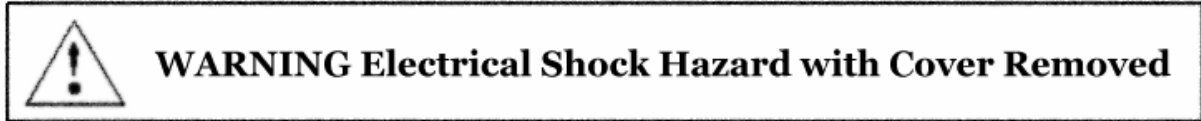

Figure 31 - Advanced

OPERATION

Important Safety and Warning Information



The T-DAR system may contain, produce and present the hazard for electrical shock or burns with the cover removed. There are no user serviceable parts under the interior panels. Only trained authorized personnel may perform maintenance or repair.

Underwriters Laboratories Inc. has not tested the performance or reliability of the security or signaling aspects of this product. UL has only tested for fire, shock and casualty hazards as outlined in UL's Standard for Safety UL 60950-1. UL Certification does not cover the performance or reliability of the security or signaling aspects of this product. **UL MAKES NO REPRESENTATIONS, WARRANTIES OR CERTIFICATIONS WHATSOEVER REGARDING THE PERFORMANCE OR RELIABILITY OF ANY SECURITY OR SIGNALING RELATED FUNCTIONS OF THIS PRODUCT.**

Units are for use in **RESTRICTED ACCESS LOCATIONS.**

Critical elements to maintain proper T-DAR operation

Once correctly installed, the T-DAR mantrap system does a superb job of detecting violations of access control security systems. In order to accomplish this task, the T-DAR requires several critical elements and/or signals from the doors and the access control system as detailed in this manual. If, after installation, environmental or access control signal conditions become degraded, the T-DAR system may not operate properly. Consult the Installation/Setup sections of this manual for the correct values for these elements. Some important factors that could cause improper operation are:

1. Changing the wiring or programming of the access control system may cause improper output to the T-DAR system.

When changes are made to the access control system, check that the T-DAR control unit is still receiving and sending the proper signals. The input and output signals can be checked by observing Event count on the Monitor tab of the user interface or by simply testing the mantrap for proper operation. Testing the mantrap is easily done by passing through it normally, inward and outward. In addition, ensure the tailgate triggers when a tailgate occurs.

2. Door contact/door position switch signals must be immediate.

These signals must be sent to the T-DAR unit at the same time that the door is opened. Unless it can be verified that the access control system can give immediate door open signals, the T-DAR unit must have an independent circuit for this function that allows isolation from the access control system. It is recommended that mechanical switches of the roller and plunger types be avoided in favor of magnetic switch door contacts.

3. Lighting Conditions may have changed.

A. Adequate and consistent lighting is required for accurate operation of the T-DAR system. The T-DAR system uses stereo video analysis to determine three-dimensional characteristics of targets and requires sufficient lighting to perform this task. Equal and consistent lighting allows the system to identify and track targets in all areas of the detection pattern.

B. Sunlight exposure to the protected area may have changed. Direct sunlight exposure in protected areas can under certain conditions cause improper operation of the T-DAR unit and may need to be mitigated.

4. **Power to existing event cameras may have changed.**
Event cameras on multi-door systems (T-2000) must be powered with AC (alternating current) on the same leg of the 3-Phase line. This allows the independent video signals to be synced. Failure to have synced video signals will result in distorted and unusable event video replay clips.

5. **Temperature conditions may have changed or the T-DAR unit may need service.**

A. The T-DAR units must be placed in areas that maintain suitable temperatures to operate properly. Consult the Product Description or Specifications portions of this manual for suitable conditions for each T-DAR component. The CB100/200 Control Unit utilizes long life fans but these may need service after a number of years.

Note: The visible LED's on the front of the CB210/CB410 provide visual indication of high temperature conditions. LED 3 will turn yellow or red if the T-DAR control box is over the recommended temperature. In addition, the S100 Annunciator red signal light flashes continuously if the T-DAR unit has shutdown.

Front Panel Indicator LED's on the CB210

LED #	Use		Description
1	T-DAR Status	Off Flashing Yellow Flashing Green Flashing Red Any color- <i>steady state</i>	Firmware and software not running Firmware running-software in self-check Firmware and software running-Normal Firmware running-software stopped Firmware and software stopped
2	Ethernet connection	Off Green	No Ethernet connection Ethernet connection established*
3	Processor Temperature**	Green Yellow Red Flashing Red	Less than 55° C-Normal 56° C to 65° 66° to 70° C Over 70° C
4	Power	Off Green Red	No Power to the unit Power supplied and breaker is not tripped Power supplied and breaker is tripped

Figure 32 - LED Indicators

* LED 2 may take a few seconds to indicate an Ethernet connection or to turn off after the connection is removed.

** If the Processor temperature is over 70°C, the Annunciator will produce a timed alarm signal

Programming the Annunciator

Voice Announcements may be changed to suit the installation.

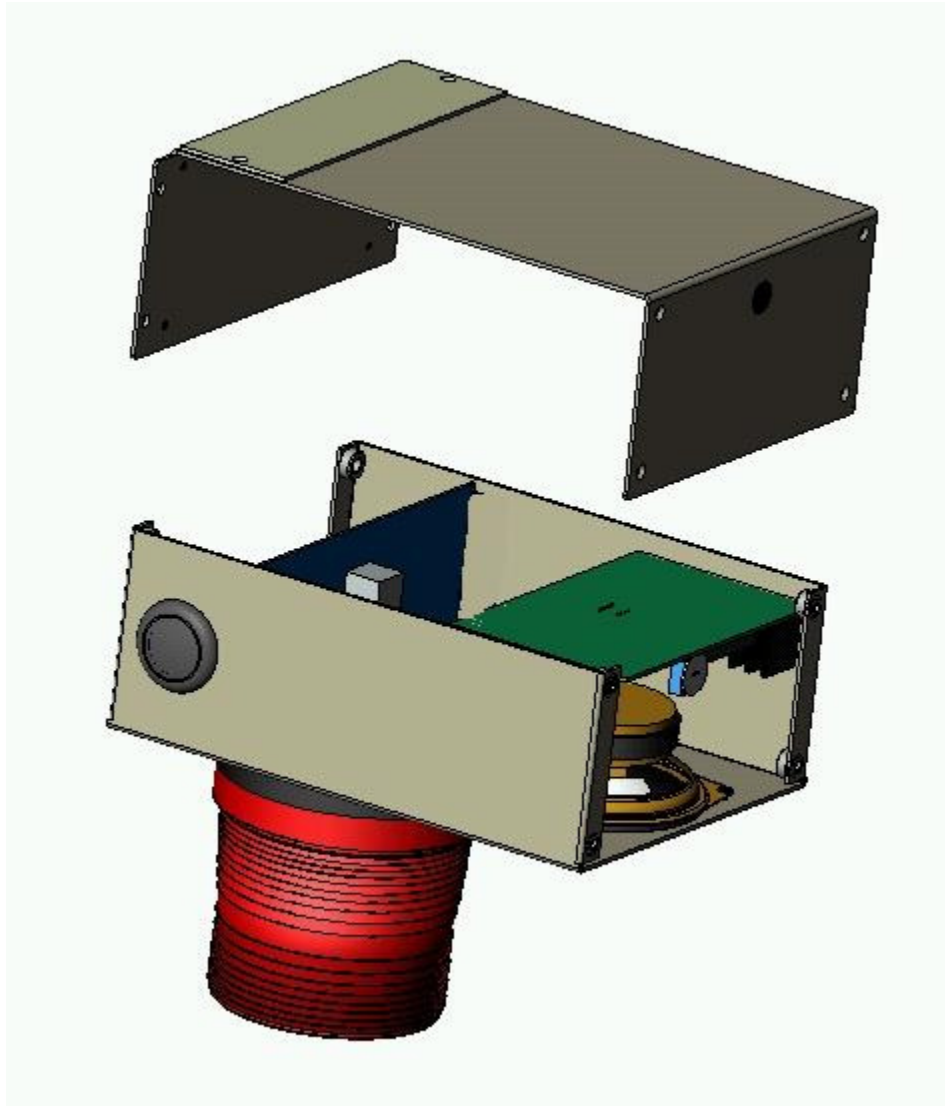

Figure 33 - Annunciator Internal View

To change the Voice Announcement via microphone:

- b) Gain access to the printed circuit board within the Annunciator. Remove the (6) 6/32 Phillips head screws that attach the top cover.
- c) Ensure that JP1 is set **MIC.**, JP2 is set **REPEAT**, JP3 is set to **RECORD** and JP4 is set to **SIREN**.
- d) Locate the record switch **SW1** in the rear right corner of the circuit board.
- e) Select, via the one of the four **STR** DIP switches, the message you wish to record over. This message will repeat until its switch is restored.

- f) Depress and hold the record switch **SW1** and speak the new message clearly into the unit.
- g) Release the record switch when complete. Your new message should now be playing repeatedly.
- h) If satisfied with the new message, restore the **STR** DIP switch selected for reprogramming to its normal off position.
- i) Replace and secure the cover with the (6) 6/32 Phillips head screws.

**Please see the figure on the following page for component locations.
(Shown in default Microphone Programmable position)**

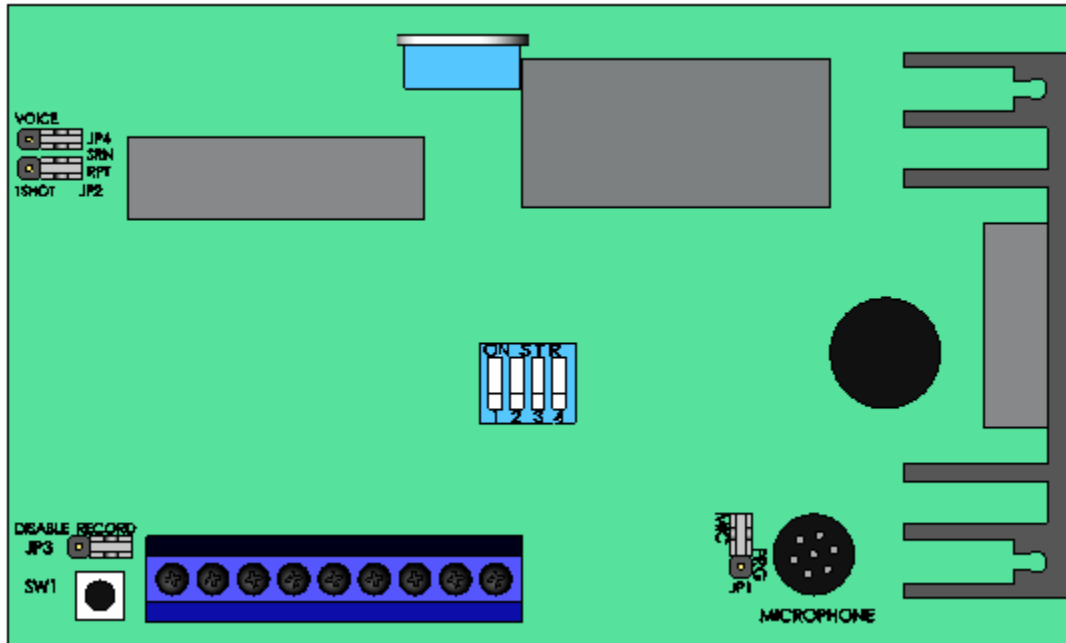

Figure 34- Annunciator PCB

To change the Voice Announcement via audio input jack:

- a) Gain access to the printed circuit board within the Annunciator.
Remove the (6) 6/32 Phillips head screws that attach the top cover.

Maintenance

Periodically, the unit should be inspected for any signs of damage or build up of debris on the camera head as well as the intake and exhaust ports of the controller. Remove any debris with a damp cloth.

Troubleshooting

This section provides fundamental hardware troubleshooting for the T-DAR. For problems that are not covered in this section, contact your local Newton Security Inc. Authorized Distributor.

Tips for getting a good image

- ◆ Make sure that the light is consistently illuminated across the entire mantrap.
- ◆ Ensure the floor, walls, and surrounding physical environment are free from bright reflections. Bright reflections may cause the T-DAR system to perceive a person when the mantrap is empty. Bright reflections should be physically minimized. Loosening the T-DAR settings may be required to overcome a reflection issue. Problems with bright reflections can be reduced by increasing the Minimum head size to approximately 400, so that the reflection is too small to be considered the head of a person. Additionally the scan zone region can be decreased so that it does not encompass the reflection. Do not use this method if the region size has to be reduced, so far, that security is compromised. The mantrap Scan Zone regions should be large enough that a person standing anywhere in the mantrap can be detected.

Use Stereo Tracking Heads with different focal lengths for taller ceilings. Check with your Newton Security Inc. Authorized Distributor regarding availability of Stereo Tracking Heads for special installations.

Lighting

The minimum acceptable amount of lighting for proper operation of the T-DAR system is 30fc (foot candle) or 300lux measured approximately 48 inches above the floor and at arms length from the body. If the lighting is below this level, the T-DAR system requires that the lighting be increased to a level comparable to the guidance issued by the Illuminating Engineer Society of North America (IESNA) for Performance of Visual Tasks, High Contrast, which calls for approximately 30fc to 50fc (300 to 500 Lux).

Problems Communicating with the T-DAR

- ◆ The user interface will not connect with the T-DAR System

Try the following first:

- ◆ Wait 30 seconds and try reconnecting.
- ◆ Reboot the T-DAR control unit and try reconnecting (Be sure that the T-DAR control unit is fully booted; this takes approximately three minutes)
- ◆ Check the Ethernet cable to ensure it is connected properly
- ◆ Ensure that an Ethernet connection is established (this is verified by a green light on LED 2)
- ◆ Make sure that only one copy of the user interface is installed on the laptop or PC.
- ◆ Ensure you are using a crossover Ethernet cable when connecting directly to a laptop or PC
- ◆ Make sure your Laptop or PC is set to 10.0.0. # with a sub -mask of 255.0.0.0 when connecting directly
- ◆ Turn off the computer, restart, and try again.

If the above suggestions do not provide results, follow the procedures below to further troubleshoot communications:

Call your Newton Security Inc. Authorized Distributor

Arrange with your local distributor to substitute a working T-DAR unit and laptop to determine where the problem exists.

Imaging Problems

To assist in troubleshooting, connect the T-DAR to any NTSC color monitor. Use a BNC cable and adapters to connect from the monitor to the Imager Out terminal on the top panel of the T-DAR unit. This will allow you see what the Imager is viewing in terms of bright spots, reflections, and other imaging problems.

<ul style="list-style-type: none">◆ The Image Is Entirely Blue	<ul style="list-style-type: none">◆ Make sure the BNC cable is connected properly to the Camera Head and to the Control Unit.◆ Be sure that the camera sync cable (Cat5, straight through) is properly connected.◆ Ensure that the monitor is connected and that 'Show camera views' is selected on the user interface. Connect with the user interface. Open the monitor tab and select 'Show camera views' for the camera.◆ While connected with the user interface, turn to the Installer Camera Settings tab and view the appropriate camera in the Viewing Window.◆ Connect the camera BNC directly to the monitor to check for a proper video image. Try a different cable if necessary.◆ Contact your Newton Security Inc. Authorized Distributor. *
<ul style="list-style-type: none">◆ The Image Is Black	<ul style="list-style-type: none">◆ Make sure the BNC cable and Power Control cable is properly connected to the system unit and to the Camera Head.◆ Be sure that the camera sync cable (Cat5, straight through) is properly connected.◆ Ensure that the monitor is on, is connected, and that 'Show camera views' is selected on the user interface. Connect with the user interface. Open the monitor tab and select 'Show camera views' for this camera.◆ Point the Imager at a bright light. If the live image is entirely black, then contact your Newton Security Inc. Authorized Distributor.*

<p>◆ Random Pixels Appear In The Image</p>	<p>This is commonly caused by electrical noise generated by motors and controllers connected to or near the T-DAR Control Unit or Camera Head/Cables. This random image noise can adversely affect performance and should be minimized.</p> <p>Use the following guide to try to isolate the cause of the noise:</p> <p>STEP 1: The idea in this step is to determine what a normal image looks like for comparison. Try to electrically isolate the T-DAR Series to determine a known or normal visual pattern on the video monitor. If it is not possible to electrically isolate the unit at its normal mounting position, take the T-DAR Series away from the area where inspections are being performed and connect it to another Camera Head. Determine the normal image.</p> <p>STEP 2: Determine the noise. Reconnect to the T-DARA normally. Block the lens to produce a dark image so that you can see the electrically induced noise.</p>
--	--

IMAGING PROBLEMS (CONTINUED)	
<ul style="list-style-type: none"> ◆ Random Pixels Appear In the Video Output (continued) 	<p>Remove the unit from its current mounting- repeat Step 2.</p> <p>Change the power source-repeat Step 2.</p> <p>Change the ground connections-repeat Step 2.</p> <p>Disconnect controllers and drives one at a time from the control panel-repeat Step 2.</p> <p>Physically move the T-DAR (or Camera Head cables) away from the machine-repeat Step 2.</p> <p>Continue with these suggestions until the source of the noise is discovered.</p> <p>Note: A common solution is to isolate the ground from the grounds of heavy machinery.</p>
<ul style="list-style-type: none"> ◆ The Image Is Too Dark 	<ul style="list-style-type: none"> ◆ Increase the overall light by increasing the intensity of the illumination source in the mantrap or by increasing the number of illumination sources. ◆ Replace the Stereo Camera Heads if the problem persists.
<ul style="list-style-type: none"> ◆ The Image Is Too Bright 	<ul style="list-style-type: none"> ◆ Decrease the illumination source or number of sources. ◆ Replace the Stereo Camera Head if problem persists.
<ul style="list-style-type: none"> ◆ The Image Is Blurry 	<p>You may need to:</p> <ul style="list-style-type: none"> ◆ Clean the lens. <p>A clean lens ensures that the images acquired by the Camera Heads are accurate. This is important to the performance. The lens can be cleaned with a commercial glass cleaner and a lint-free cloth. You may need to clean the lens daily in dusty environments.</p> <ul style="list-style-type: none"> ◆ Move the Stereo Tracking Head. <p>The wrong heads may be installed for this mantrap. Verify the correct head is being used. If correct, verify the height and placements are accurate. If the cameras and placements are correct then contact your Newton Security Inc. Authorized Distributor.*</p>

All Monitored Events Are Failing

If a working installation suddenly returns failed inspections for all or most of the mantrap monitoring, a change in lighting conditions or a new surface may have been introduced into the mantrap. Recalibrate both camera heads to adapt to this new environment. T-DAR Stereo Camera Heads may have been bumped or have had their views obstructed; be sure they are in place and free from obstruction. Observe the video output of all the tracking cameras to find abnormalities.

◆ Check the lighting conditions	A light source that dims over time or a light source that has gone out completely can affect the performance. Make sure that your light sources are strong and positioned correctly. Good lighting is essential to getting a good image and to security monitoring performance. To see the effect of the lighting, select an output that best displays the problem and monitor the live image.
◆ Check to see if the Stereo Camera Head is out of position	Put the Camera Head to its original position. If you are unsure, reposition it as close to the original location as possible. If you cannot reposition the unit properly, connect the Control Unit to the host computer and redo setup in the User Interface

DETAILED SPECIFICATIONS - CB110MT/210MT/410MT

Power Specifications

Operating Voltage Range	24 VDC \pm 10%
Peak Voltage (Non-continuous)	30 VDC
Maximum. Input Current	20mA@12VDC, 10mA@24VDC

DC Input Specifications

Minimum Pulse Width	0.4 mSec
ON Voltage Level	>10 VDC
OFF Voltage Level	< 2 VDC
Input Impedance	2.2 K Ω
Minimum ON Current	>10 mA
Maximum OFF Current	<0.1mA
OFF to ON Response	0.2 mS Typical
ON to OFF Response	0.2 mS, Typical
Commons	Three Commons: General 2, Portal/Head 1&2

Relay Output Specifications

Minimum-Maximum Voltage Range	0 – 30 VDC
Peak Voltage	<50 VDC
Maximum Current (resistive)	2 A
Maximum Inrush Current	5 A
OFF to ON Response	0.2 mSec Typical
ON to OFF Response	0.2 mSec Typical

Auxiliary Power Outputs

+5 VDC	Incorporated overcurrent breaker
+12 VDC	Incorporated overcurrent breaker
+24 VDC	Incorporated overcurrent breaker

Control Unit Panel Connections

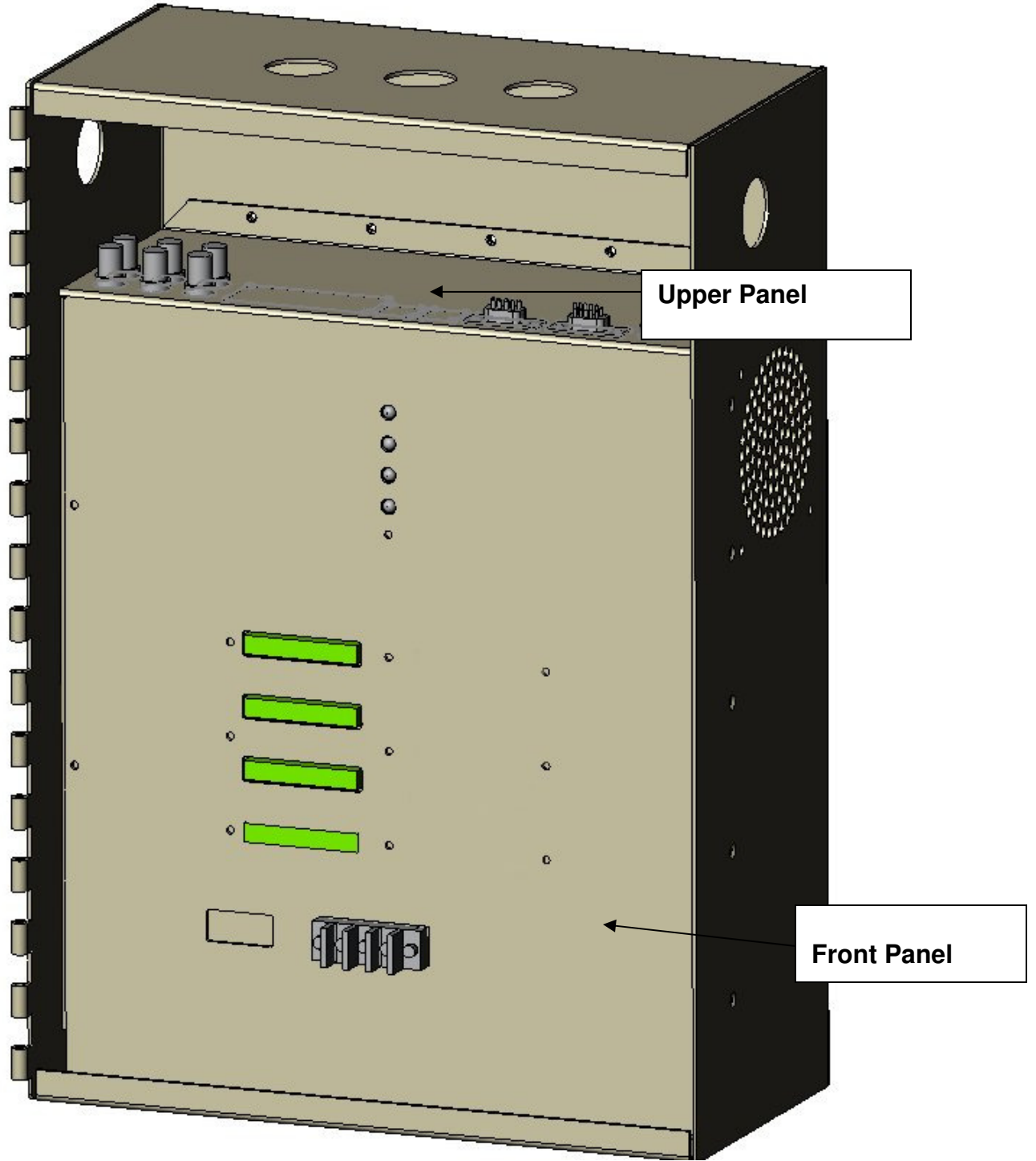

Figure 35 - Control Unit Connections

Upper Front Panel Connections

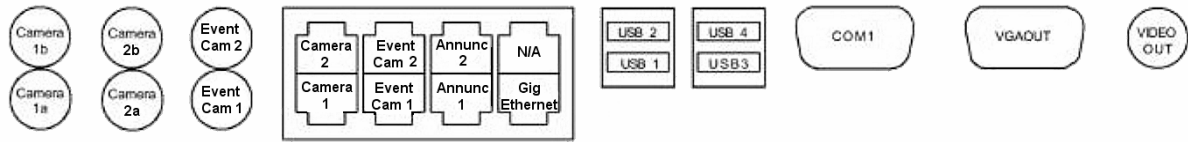

Figure 36 – Upper Panel Connections

Camera 1a: Input, BNC connector from Stereo Camera Head1, camera a. Used for secure door.

Camera 1b: Input, BNC connector from Stereo Camera Head 1, camera b. Used for secure door.

Camera 2a: Input, BNC connector from Stereo Camera Head 2, camera a. Used for public door.

Camera 2b: Input, BNC connector from Stereo Camera Head 2, camera b. Used for public door.

Event Cam 1: Input, BNC connector from external Camera for Event Capture
Event Cam 2: RJ-45 is not used for mantraps.

Camera 1 RJ-45: Interface, Standard 10BaseT Cat-5 Ethernet cable to Stereo Camera Head 1 for Power/Control. Used for secure door.

Camera 2 RJ-45: Interface, Standard 10BaseT Cat-5 Ethernet cable to Stereo Camera Head 2 for Power/Control. Used for public door.

Annunc 1: RJ-45 Interface, Standard 10BaseT Cat-5 Ethernet cable to Annunciator for Power/Control.

Annunc 2: RJ-45 Interface, Not used for mantraps.

Gig Ethernet: Gigabit Ethernet Interface, Standard Cat-5 Ethernet cable to Local Area Network (LAN)

USB 1-4: Interface, Standard USB-2 communications for flash memory, mouse, keyboard, etc.

Com 1: Interface, RS-232 interface for secondary communications with processor

VGA Out: Output, 15 pin VGA for connection of computer monitor for local system control.

Video Out: Output, BNC connector to video monitor for set-up and monitoring

Front Panel Connections

T-DAR[®]

CB210

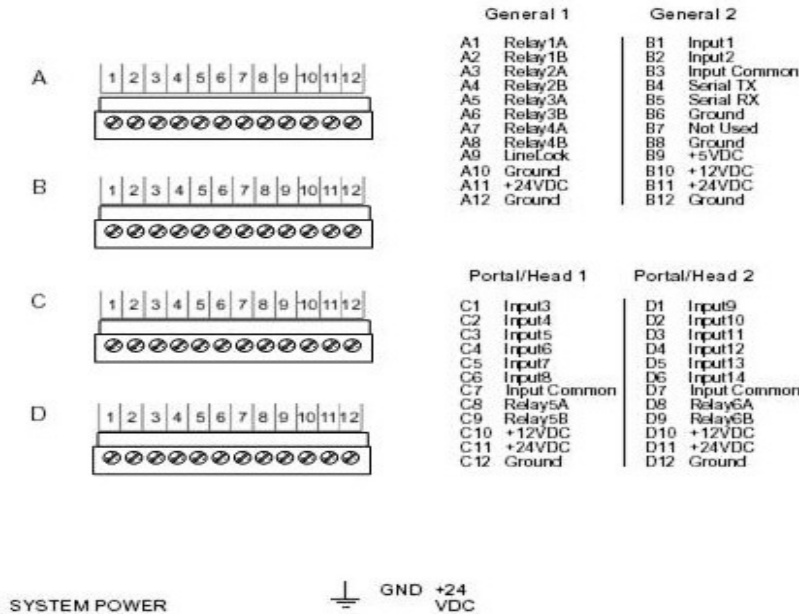

Figure 37 - Control Unit Connections

Phoenix Style connectors, top to bottom

CONNECTOR A, General 1

Pins 1-2: Relay 1 A&B, secure door lock output. Form A relay contact. Relay will remain closed unless the T-DAR receives a public valid grant signal or secure valid grant signal and the T-DAR approves access.

Pins 3-4: Relay 2 A&B, public door lock output. Form A relay contact. Relay will remain open unless the secure door is open.

Pins 5-8: Relay 3-4 A&B, general purpose Form A relay contacts, normally open

Pin 9: Line Lock, for use with 6-30 VAC power for syncing to local power grid

Pin 10: System GND, for use with Line Lock

Pin 11: +24VDC

Pin 12: System GND

CONNECTOR B, General 2

Pin 1: Input, turns alarm off when triggered.

Pin 2: Not Used

Pin 3: Input, Sets logic level for inputs on General Connector 2. Connect to Ground for Logic High (+12V=Trigger) on inputs. Connect to +12V for Logic Low (GND = Trigger)

- Pin 4:** Rs232 Output, serial data
- Pin 5:** Rs232Input, serial data
- Pin 6:** System GND
- Pin 7:** Not Used
- Pin 8:** System GND
- Pin 9:** Output, System +5VDC
- Pin 10:** Output, System +12VDC
- Pin 11:** Output, System +24VDC
- Pin 12:** System GND

CONNECTOR C, Portal 1

- Pin 1:** Input 3, Secure Valid Access Signal
- Pin 2:** Input 4, Public Door Contact
- Pin 3:** Input 5, Public Valid Access Signal
- Pin 4:** Input 6, Secure Door Contact
- Pin 5:** Input 7, Not Used
- Pin 6:** Input 8, Not Used
- Pin 7:** Input, Sets logic level for inputs on Portal 1 Connector. Connect to Ground for Logic High (+12V=Trigger) on inputs. Connect to +12V for Logic Low (GND = Trigger).
- Pin 8-9:** Relay 5 A&B, general purpose Form A relay contacts, normally open
- Pin 10:** Output, System +12VDC
- Pin 11:** Output, System +24VDC
- Pin 12:** System GND

CONNECTOR D, Portal 2

- Pin 1:** Input 9, Not Used
- Pin 2:** Input 10, Not Used
- Pin 3:** Input 11, Not Used
- Pin 4:** Input 12, Not Used
- Pin 5:** Input 13, Encoder A, quadrature data from door position sensor
- Pin 6:** Input 14, Encoder B, quadrature data from door position sensor
- Pin 7:** Input, Sets logic level for inputs on Portal 2 Connector. Connect to +12V when **using a door encoder**; for Logic Low (GND = Trigger). Connect to Ground for Logic High (+12V=Trigger) on inputs.
- Pin 8-9:** Relay 5 A&B, general purpose Form A relay contacts, normally open
- Pin 10:** Output, System +12VDC
- Pin 11:** Output, System +24VDC
- Pin 12:** System GND

SYSTEM POWER

- GND:** Connection to Ground on 24VDC +/-10% 8amp Power Supply (external)
- +24VDC:** Connection to +24VDC +/-10% 8ampPower Supply (external)
- EARTH:** Connection to external ground connection, as necessary

Connection details

Video Out

BNC Connector—System output in video format. Output is in RS170 (NTSC). Optional PAL output is available on special order. This video output is used for displaying inspection results of the T-DAR system in real time and processed video. The Video Out output is not available for RGB or S-Video,

Input 1

The alarm bypass is an opt-isolated input used to reset the alarm event for the T-DAR mantrap. Changing the state of this input stops the audio output from the Annunciator Unit. While enabling this input, the strobe will flash and the T-DAR will allow multiple persons to pass through the mantrap after a valid public access grant. A secure valid grant will not allow the secure door to be opened while the bypass is enabled.

Relay 1

Form-factors A relay for control of the secure door lock. This relay is normally closed and opens only after certain conditions are met, including a valid public or secure access grant. Relay 1 will never open when the public door is open or unlocked.

Relay 2

Form-factors A relay for control of the public door lock. This relay is normally open and closes only when the secure is open or unlocked.

Relays 3 - 6

The T-DAR unit is equipped with four form-factors A relays that can be configured to activate on various user selectable conditions. Also, the normal state of these relays is user definable to allow for greater flexibility in integrating the system with a variety of access control systems. Four of the relays are located on the General 1 connector, and the fifth (sixth) relay is located on the Portal connector.

Line Lock Input

The T-DAR Series uses the Line Lock input to sync with the local power grid. This input is useful in applications where the video input to the T-DAR system needs to be synchronized with the lighting, such as fluorescent or other types of flickering lighting.

Input Common

The common terminal is used to define the operation of the inputs on all four connectors, independently. If a dry contact is to be used for bypass on the

General 2 connector, a small jumper wire will be installed between the +12VDC terminal and the common terminal. This allows the mantrap bypass terminal to generate a reference voltage that can be sensed when the terminal is shorted to ground.

If a wet contact is to be used, the small jumper wire would be installed between the common terminal and the ground terminal on the General 2 connector. Also, a bond wire from the external power supplies ground terminal will need to be placed in the Ground terminal as well to provide for ground bonding.

RS232 TX

The T-DAR Series reads data in from external sources or outputs data from the vision system via a RS422 serial connections found on the Phoenix I/O Connectors. Use the specific section of this user's guide for application details on available inputs, outputs and configuration of this port.

Input 4 and 6

These are door contacts used to monitor the status of the door position switches (open or closed). Inputs 4 and 6 monitor the public and secure doors, respectively. This should be a dedicated switch, and normally requires the installation of a double pole/double throw door position switch.

When using double doors on the public side, door position switches should be used on each door. Connect these switches in series so that when either door opens, relay 4 will be triggered. The same is true for the secure side.

Input 3 and 5

The valid access grant switches must be electrically isolated from the access control system to allow for proper operation. This will typically require the installation of a double pole/double throw relay that controls the lock and also provides an output to the T-DAR system. It should be noted that it is acceptable for the T-DAR to receive the signal before the door is unlocked, but not after. Failure to use isolated circuits or using access control system auxiliary outputs/relays to simulate the valid access switch activity may result in poor system performance. There can be no noticeable latency in the receipt of valid access grant switch signals by T-DAR.

The valid access grant switch will connect to the Portal Digital Input terminal and to either ground or +12v (or applicable source voltage) dependant upon installation type.

Input 2 and 7 -14

Not Used

I100 Door Position Encoder

A high resolution door position sensor provides digital-quadrature data to determine door position, with respect to the overhead stereo cameras. The Door Position Encoder is used on an inward swinging public door only. If inward swinging double doors are used at the public entrance two encoders will be required.

To install the Door Position Encoder use a straight thru Cat-5 with a RJ-45 connector on the encoder end and flying leads at the T-DAR Control Unit. The leads from the Cat-5 will connect to the D connector on the TDAR Control Unit as shown in the diagram below.

Jumper Input Common (D7) to +12VDC (D10)

Pins		Portal 2; Connector D		
5	Input 13	Bl/Wh	Blue CAT-5	
6	Input 14	Gr/Wh	Blue CAT-5	
10	+12 Volt	Br,Br/Wh	Blue CAT-5	+Encoder
12	Ground	Or,Or/Wh,Gr,Bl	Blue CAT-5	- Encoder

Figure 38—pin out for encoder Cat-5



Figure 39 –Position of Encoder (Public door only)

T-DAR Dual Digital Inputs

The T-DAR uses dual polarity opto-isolators on all digital inputs. All inputs can be used as either sinking or sourcing inputs.

Note: as there is a single common for the entire set of inputs, all inputs must be configured as either sourcing or sinking.

It is not possible to mix the inputs between sourcing and sinking.

The following diagrams illustrate the typical installation for each of the types of input:

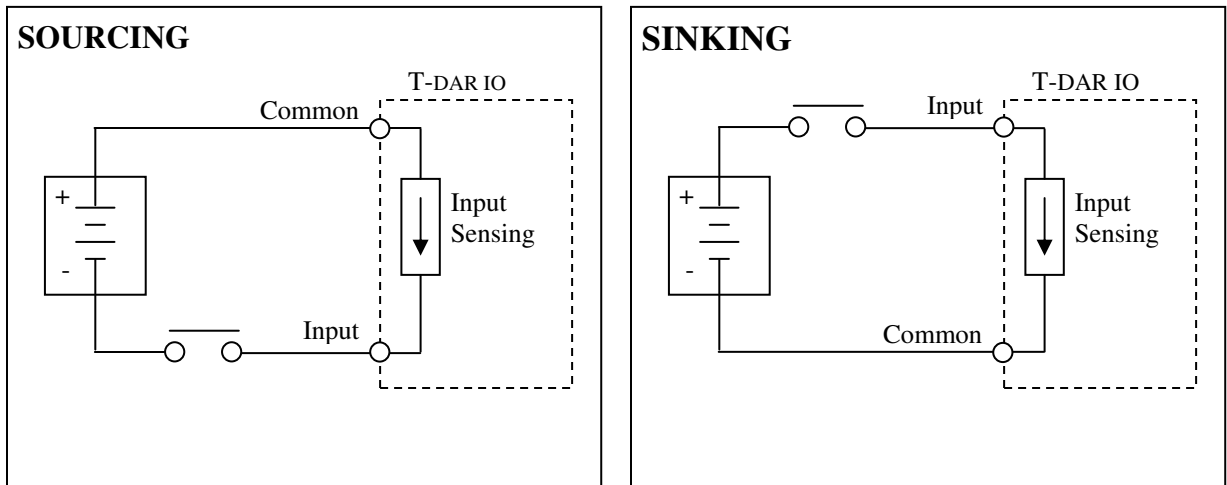

Figure 40 - Sourcing/Sinking Inputs

T-DAR Digital Outputs

The T-DAR uses relays for outputs. When the relay is triggered, connection points A & B are closed and current is allowed to pass. Applications should not exceed 3 amps.

The following diagram illustrates the typical installation for the sinking type of output:

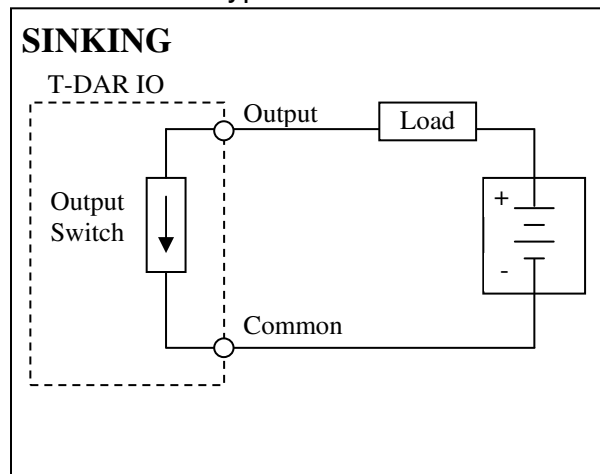

Figure 41- Sinking Outputs

MK200B Stereo Camera Mounting Kit - Installation Guide

Overview

This mounting kit is designed to install a T-DAR stereo head camera safely and attractively in a standard acoustical tile ceiling.

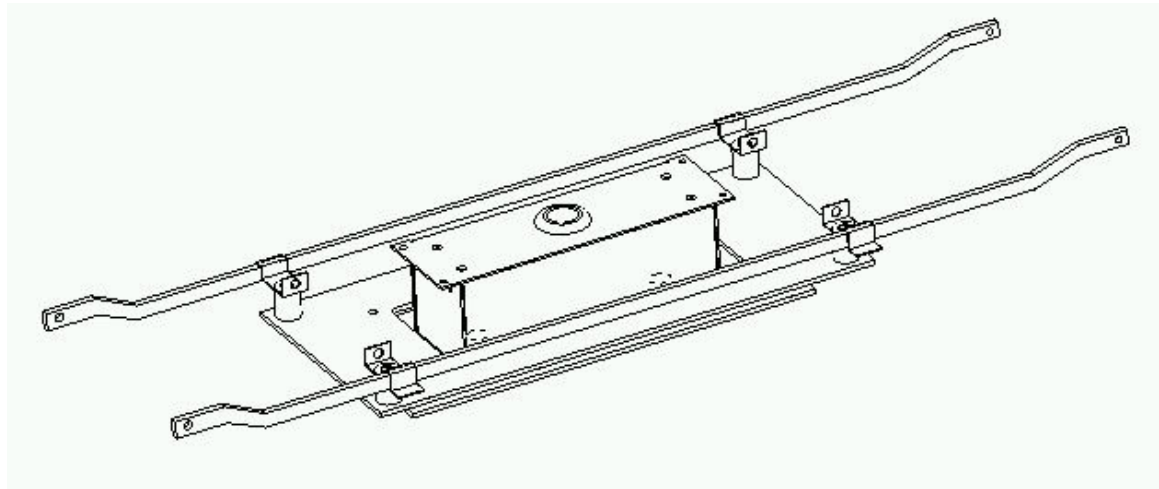

Figure 1 – Completed assembly

Getting Started

Refer to your T-DAR installation and operation manual for recommended camera locations with respect to the entry door.

Check for obstructions inside the ceiling such as ductwork, existing electrical fixtures, and so forth before choosing the final camera location. The camera will extend about 3.5" (9 cm) above the tile ceiling.

Required Hardware

Each mounting kit should contain the following:

- (1) Lower mounting plate (two round holes)
- (1) Upper mounting plate (large rectangular opening)
- (2) Caddy® 512 snap-on fixture hangers
- (4) Clips and spacers
- (8) 1/4-20 x 1.5" flat socket cap screws
- (4) 4-40 x 3/8" flat socket cap screws

You will also need:

- Small handsaw
- Drill
- Phillips screwdriver, 5/32" (4mm) hex key, and a 1/16" hex key.

Panel Cutting

Mark and cut a hole in the tile to match the layout dimensions. The camera center is indicated for your convenience when measuring. It is expedient to simply use the upper plate for this; the cutout is the same.

Initial Assembly

Use the four small 4-40 screws to attach the lower mounting plate to the camera.

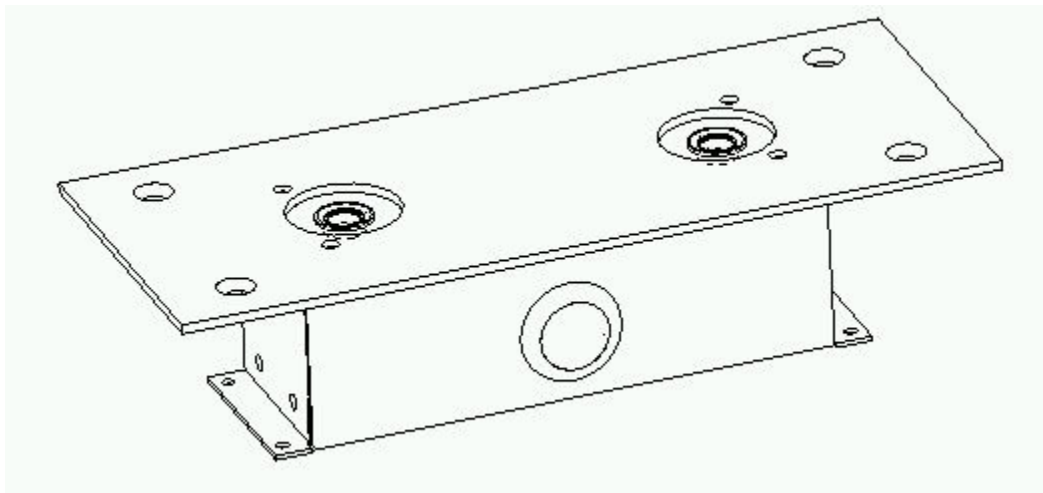

Figure 2 – Lower plate attached to camera

With the tile out of the ceiling grid, snap the fixture hangers over the grid "T" section as shown.

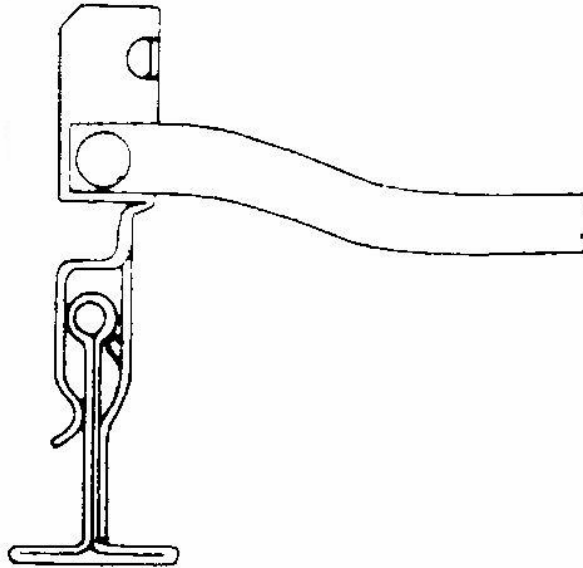

Figure 3 – Snap on fixture hanger detail

Adjust the clips on the upper plate to match the fixture hanger orientation. Note that the clips can swivel on both the fixture hanger and the upper plate to match the ceiling grid layout.

Align the upper plate and fixture hangers with the tile in place to get ready for the next step.

Final Assembly

Start with the upper plate in the ceiling, locked to the fixture clips and hangers.

Then slide the camera into the hole from underneath, and lock the plates together with the (4) 1/4-20 x 1.5" socket cap screws.

In some areas you may be required to wire anchor the camera and fixture hangers. Check your local building codes.

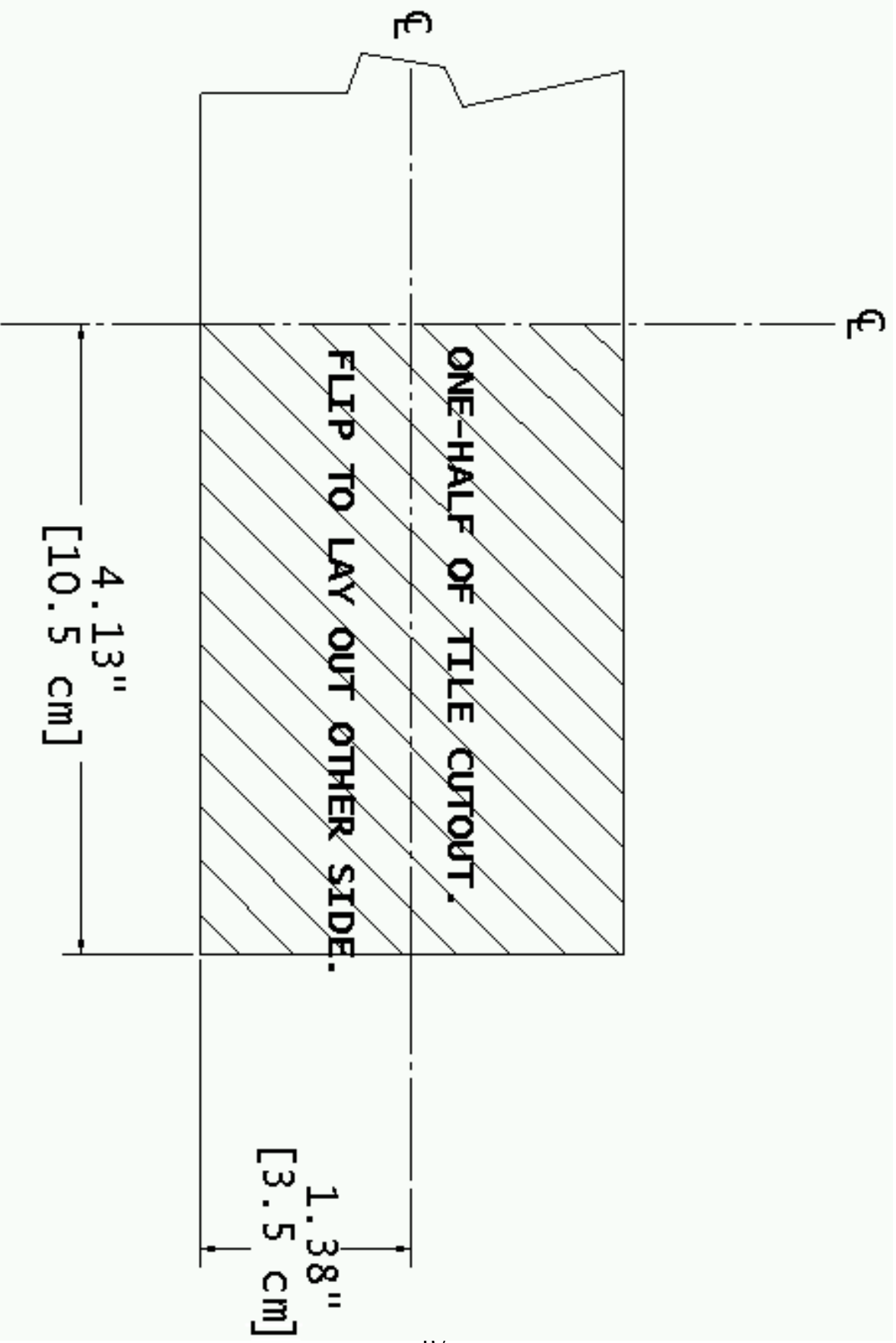

Known Issues and installation Tips

When using an electric solenoid locks, reverse voltage diodes across the solenoid terminals must be used to reduce voltage feedback to the system.

When mounting the TDAR on the wall or cabinet, ensure that there is at least 6 inches between each TDAR or any other physical barrier for proper ventilation. Do not mount one T-DAR Control Unit with its heated exhaust able to enter the fan intake of another T-DAR Control Unit.

The return signal needs to be instant from the access control system for the TDAR to alarm properly

Labeling the camera and Ethernet cables correctly on both ends will help minimize troubleshooting time, due to swapped cables

The area where the camera will be viewing needs to be very well lit. Lighting conditions can not vary during operation. If lighting conditions change, the T-DAR unit must be recalibrated to accept the changed conditions.

Be sure to connect the jumper between Input Common and the correct reference connection (12V or ground)

Failure to supply Line lock input signal if low frequency fluorescents are utilized in the installation may cause erratic system operation. (See below)

LINELOCK INPUT

Required if Low Frequency Fluorescent Lighting is utilized in the installation

The T-DAR™ system requires an input of low voltage AC from a source that also supplies the lighting for the installation (as shown in the diagram below). This low voltage (6 to 30VAC) AC signal is required to allow the cameras to be in sync with the low frequency fluorescent lighting. Failure to provide this signal to the T-DAR may cause erratic behavior in the system.

Any 6 to 30VAC signal will provide the required synchronization of the T-DAR to the low frequency fluorescent lighting. A small transformer is provided with the T-DAR system and can be used to provide this signal; in addition, any other source of low voltage AC (6 to 30VAC) that is available can also be utilized. Low voltage DC will not provide the required LineLock signal; use low voltage AC only.

CAUTION!

Do **not** provide 110/220 VAC to the T-DAR unit LineLock input. This will damage the unit.

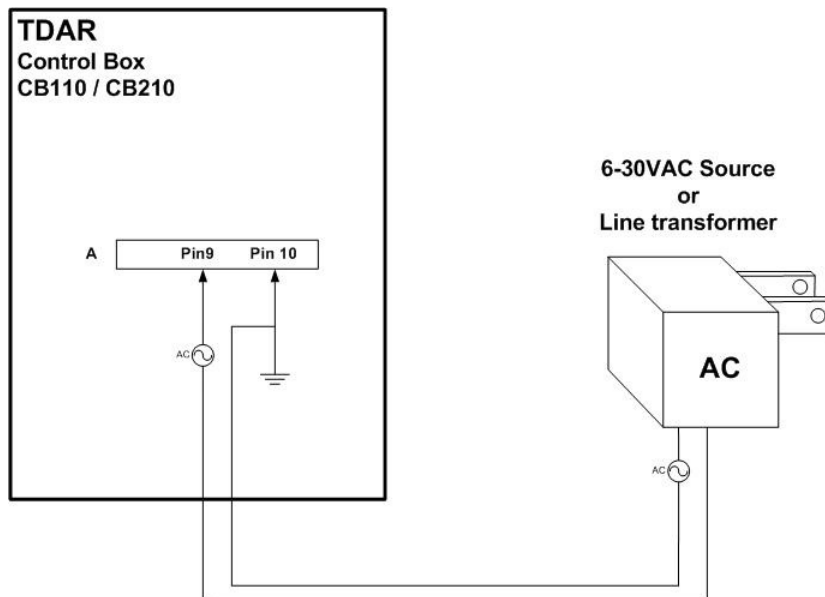

About Fluorescent Lighting:

Older style fluorescent lights turn on and off the light output at the AC line frequency: 50 or 60 Hz depending on the area of the world. Since cameras operate at a similar frequency, this rapid cycling on and off of the lights can cause erratic behavior in the T-DAR cameras and requires synchronization.

Newer style high frequency fluorescent lights operate at much higher frequencies than do the T-DAR cameras and do not affect the T-DAR cameras; no LineLock signal is required.

INDEX

- 3 Head Mantrap 35, 39, 43
- 4 Head Mantrap 35, 39, 43
- 4 or More Head Mantrap 35, 39, 43
- Access Grant Switch 41
- Advanced Tab 72
- Alarm..... 60, 62
- Alarm Events 60, 61, 62
- Annunciator.....
..... 17, 25, 32, 38, 45, 60, 76- 78
- Applications 2, 41, 47
- Biometrics 11
- BNC..... 15, 19, 23, 37, 38, 81, 87, 90
- Bypass 46, 90, 91
- Camera Chart 36
- Capturing Events 60, 61, 63
- Cart Sensitivity..... 2, 11, 14, 66, 67
- CB210..... 15, 75, 76, 85
- Change Password..... 62, 63, 68, 70
- Common 40-43, 82-85, 90-93, 98
- Configuration ... 11, 13, 53, 54, 64, 65
- Configure Connection 47, 49, 56
- Connect 40, 47- 51, 56, 80
- Connecting Controller..32, 39, 48, 51
- Connection Access Control.... 32, 40
- Connection Laptop/Lan..... 56
- Connection Menu 52
- Crawler Sensitivity 65- 67
- Crawling..... 65, 66
- DC200..... 19,25,36
- Debug Tab 57
- Digital Inputs 93
- Direct Sunlight 31, 74
- Disconnect 47, 49, 55, 56
- Display 50, 51, 60- 67
- Door Control..... 69
- Door Encoder 21, 39, 47
- Door Position Switch... 29, 43, 73, 91
- Drawing a Box..... 64, 65
- EEPROM 57
- Enclosure 15, 17, 19, 21, 23, 39
- Encoder 21, 22, 39, 50, 89, 92
- Entry from Public/Exit to Public ... 65
- Ethernet 37- 39, 48, 49, 51, 76, 87
- Event Camera... 23, 24, 39, 60, 61, 75
- Exit..... 38, 55, 65
- File Menu 54
- Fuses 85
- Good Image..... 32, 52, 79, 81- 84
- I100 13, 21, 29, 92
- Image Type..... 64
- Initial Set-Up..... 50, 59
- Input Common 42, 85, 90- 93, 98
- Input Impedance 85
- Input Specifications 85
- Installation.... 3, 28- 33, 41, 43, 69, 74
- Installer Camera Settings.. 53, 64, 65
- Installer I/O..... 53, 68
- Introduction..... 4
- IP address 47- 49, 51, 58
- Known Issues 98
- LED's 75, 76, 80
- Line Lock..... 3, 30, 88, 90, 98, 99
- Load Settings..... 54
- Local Device Placement..... 32
- Lower Front Panel 76, 86- 88
- Lower Power Panel..... 15, 17, 76, 89
- Maintenance..... 28, 73, 79
- Maximum Head Size 66, 67
- Maximum OFF Current..... 85
- Menu 49- 58
- Microphone 77, 78
- Minimum Head Size 66
- Minimum ON Current 85
- Minimum Pulse Width 85
- Min-Max Voltage Range 85
- Models 2, 11, 12
- Monitor Tab..... 60, 66, 67, 69, 74, 81
- Mounting 23, 25, 37, 38, 94, 95
- Newton Security Inc. 1
- NTSC..... 23, 33, 59, 81, 90
- OFF to ON Response 85
- OFF Voltage Level 85
- ON to OFF Response 85
- ON Voltage Level 85
- Operating Temp..... 15, 17, 75, 76
- Operating Voltage Range..... 85
- Operation..... 41, 43, 46
- Output Relays .. 40- 46, 70, 89- 91, 93

Output Specifications	85	Smart ID	11
Outputs	40- 43	Software	14, 47, 48, 51, 53, 76
Password	62, 63, 68, 70	Sourcing Inputs	93
Peak Voltage (Non-continuous)	85	Storage Temp	15
Physical Installation	28- 33, 41, 43	S-Video	90
Piggybacking	2	Switch Setup	58
Portal Common	42, 85, 90- 93, 98	T2010	13
Portal Reset	46, 90, 91	Tailgating	2, 31, 70
Power	15, 42, 50, 51, 76, 89	TCP/IP	47
Relay Connection ...40-	46, 70, 88- 91	T-DAR	2, 3, 13, 15
Relay Spare (general)	88, 89	Testing Units	51, 74
Reset Event Statistics	60, 63	Tracking Cameras (Heads)	19, 29, 33- 38, 50, 60, 84
RGB	90	Troubleshooting	79- 84, 98
RS170	90	Underwriters Laboratories	28, 73
RS422	90	Update.exe	48
S100	17, 25, 32, 38, 60, 76- 78	Update Now	59, 64, 65
Save Settings	54	Upper Front Panel	37, 86, 87
Sensitivity	64, 66, 67, 68	User Interface	47, 48, 50- 55
Setup I/O	52, 53, 60, 62, 63, 69	Video Out	32, 33, 60, 87, 90
Sinking Inputs	93	Voltage Drop	32
Sinking Output	93	Warning	28, 72
Site Considerations	31		